

Basics for practical operation

Motor protection

Necessity of motor protection
The motor's protection requirements
Protective measures

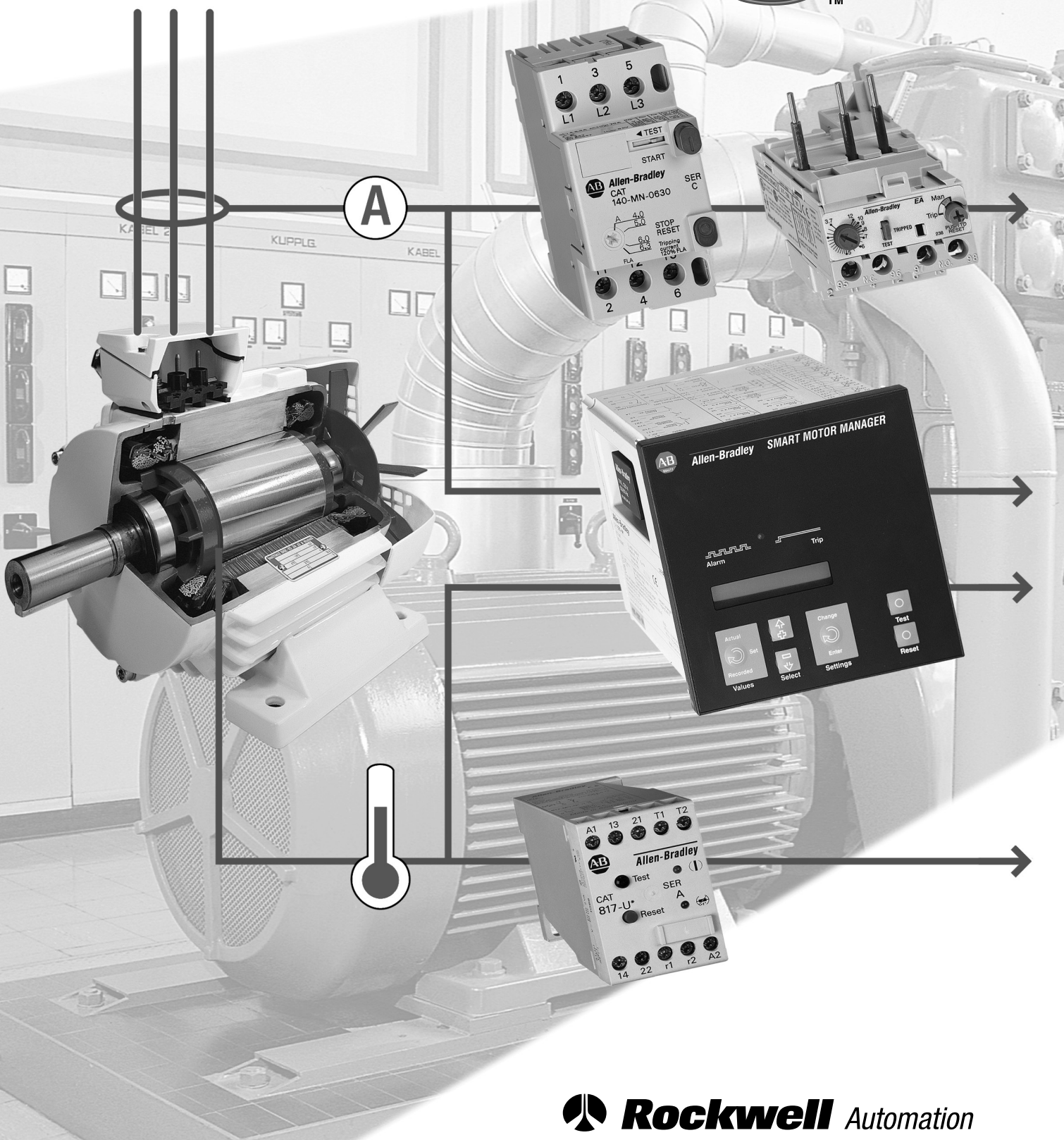

Foreword

This technical manual for “Motor Protection” is another publication on the subject of “Motor Management”.

With these fundamentals, published at regular intervals, the user will have a growing reference work on the performance and operational data required for design and application.

Topics covered include:

- Motor Starting
- Selection and Operation of Switchgear
- Communications.

The following manuals have already been published

- “Three-phase Induction Motors” - informs about structure, modes, selection and dimensioning of motors
- “Basics of Power Circuit Breakers” - additional information for the practical use of Power Circuit Breakers.

Electric motors can be found in every production process today.

The optimal use of the drives is becoming increasingly important in order to ensure cost-effective operations. “Motor Management” from Rockwell Automation will help you:

- to optimise the use of your systems
- to reduce maintenance costs
- to increase operational safety.

We are pleased that our publications may help you find economical and efficient solutions for your applications.

Copyright © 1997 by Rockwell Automation AG

All information given represents the current level of technology available and is not legally binding.

Table of contents

1	Necessity of motor protection	1.1
2	The motor's protection requirements	2.1
2.1	Temperature Rise	2.1
2.1.1	Operational behaviour	2.1
2.1.2	Limiting temperature and insulation classes	2.3
2.1.3	Insulation ageing	2.4
2.1.4	Response limits	2.5
2.1.5	Phase failure	2.6
2.1.6	Asymmetry in the network	2.8
2.1.7	Earth fault	2.9
2.1.8	Short circuit	2.9
3	The system's protection requirements	3.1
3.1	Stalling	3.1
3.2	Underload	3.1
3.3	Incorrect rotation	3.1
3.4	Motors in explosion-risk areas	3.1
3.4.1	Ignition protection type and increased safety EEx e	3.1
3.4.2	Significance of time t_E	3.2
4	Protection measures	4.1
5	Temperature-dependent protection measures	5.1
5.1	Application problems	5.1
5.1.1	Applications	5.1
5.1.2	Thermal inertia	5.1
5.2	Bimetallic sensors in the winding	5.2
5.3	PTC - sensors	5.3
5.4	Linear temperature sensors	5.4

6	Current-dependent protection	6.1
6.1	Function	6.1
6.2	Device characteristics	6.1
6.2.1	Stationary operation	6.1
6.2.2	Intermittent operation	6.2
6.3	Bimetallic protection principle	6.3
6.3.1	Function	6.3
6.3.2	Short circuit resistance	6.5
6.3.3	Single-phase operation	6.5
6.3.4	Phase failure	6.5
6.3.5	Recovery time	6.7
6.3.6	Current setting	6.8
6.3.7	Trip Free	6.9
6.4	Motor protection during heavy duty starting	6.9
6.5	Motor protection in hazardous area locations	6.10
6.6	Electronic motor protection	6.10
6.6.1	Overload protection	6.11
6.6.1.1	Thermal projection models	6.11
6.6.1.2	Current setting	6.12
6.6.1.3	Setting the tripping time	6.13
6.6.2	Special motor protection functions	6.14
6.6.2.1	Phase failure	6.14
6.6.2.2	Asymmetry	6.14
6.6.2.3	Short-to-earth	6.15
	Short-to-earth using the “Holmgreen”- method (rigidly earthed networks)	6.15
	Short-to-earth using cumulative current transformers	6.16
	Leakage protection in medium voltage networks	6.16
6.6.2.4	Short-circuit protection of medium voltage motors	6.21
6.6.3	System-protection functions	6.22
6.6.3.1	High overload and stalling	6.22
6.6.3.2	Underload	6.23
6.6.3.3	Incorrect rotation protection	6.24
6.6.3.4	Start time monitoring	6.24
6.6.3.5	Stalling during start	6.25
6.6.4	Control functions	6.26
6.6.4.1	Pre-warning	6.26
6.6.4.2	Load control	6.26
6.6.4.3	Start lock-out	6.26
6.6.4.4	Star-delta-change-over	6.27
6.6.4.5	Warm start	6.28
6.6.4.6	Possibilities for communication	6.29

6.6.5	Applications of electronic motor overloads	6.29
6.6.5.1	Low thermal inertia motors	6.29
6.6.5.2	High thermal inertia motors	6.30
6.6.5.3	Rotorcritical motors	6.30
6.6.5.4	Medium voltage motors	6.30
6.6.5.5	Slip-ring motors	6.31
6.6.5.6	Multi-stage motors	6.31
6.6.5.7	Frequency-controlled motors	6.32
6.6.5.8	Soft start	6.32
6.6.5.9	Motors with remote ventilation	6.33
6.6.5.10	Increased ambient temperature	6.33
6.6.5.11	Motors in hazardous locations	6.33
6.6.5.12	Protection of compensated motors	6.34
7	Selecting the correct motor overload	7.1
7.1	Application-dependent selection	7.2
7.2	Selection depending on motor and drive	7.3
7.3	Selection depending on ambient conditions	7.4
7.4	Selection in accordance with motor management criteria	7.5

1 Necessity for motor protection

It could be assumed that properly planned, dimensioned, installed, operated and maintained drives should not break down. In real life, however, these conditions are hardly ever ideal. The frequency of different motor damage differs since it depends on different specific operating conditions.

Statistics show that annual down times of 0.5...4% have to be expected. Most breakdowns are caused by an overload. Insulation faults leading to earth faults, turn-to-turn or winding short circuits are caused by excess voltage or contamination by dampness, oil, grease, dust or chemicals.

The approximate percentages of by these individual faults are:

- overload 30%
- insulation damage 20%
- phase failure 14%
- bearing damage 13%
- ageing 10%
- rotor damage 5%
- others 8%

Therefore, the following points must be observed to guarantee fault-free operation of an electrical drive:

- Correct design: a suitable motor has to be selected for each application.
- Professional operation: professional installation and regular maintenance are preconditions for fault-free operation.
- Good motor protection: this has to cover all possible problem areas.
 - It must not be tripped before the motor is put at risk.
 - If the motor is put at risk, the protection device has to operate before any damage occurs.
 - If damage cannot be prevented, the protection device has to operate quickly in order to restrict the extent of the damage as much as possible.

Table 1.2.1 represents a summary of the most frequent breakdown causes for motors, their extent and the possible damage caused.

Cause	Effect	Possible damage
Thermal overload: <ul style="list-style-type: none"> • extreme starting conditions • locked rotor • high overload • undervoltage • intermittent operation 	overcurrent and thus unacceptable heating-up of windings	soldered joint damage rotor cage burnt windings stator windings
Cooling problems: <ul style="list-style-type: none"> • restricted cooling • ambient temperature too high 	unacceptable heating-up	burnt windings stator windings
Electrical causes: <ul style="list-style-type: none"> • single phase conditions • unbalanced voltage • earth fault • shorted turns • winding short circuit 	unbalanced overcurrent of windings heating-up depending on motor size and bearing damage load	individual windings or parts burnt
Mechanical causes: <ul style="list-style-type: none"> • imbalance • mis-alignment • improperly installed drive (e.g., bearing load of V-belts too high) 	uneven wear of bearings	bearing damage

Tab. 1.2.1 Breakdown causes, effects and possible motor damage.

2 The motor's protection requirements

2.1 Temperature Rise

In line with applicable standards, every motor manufacturer guarantees that critical machine parts remain within the permissible temperature range during rated operation and that short-term overloads do not damage the motor.

The motor protection device, on the one hand, has to allow full use and thus the efficient operation of the motor and, on the other hand, react quickly enough in case of an overload.

2.1.1 Operational behaviour

Electrical motors are energy transformers. They take in electrical energy and transform it into mechanical energy. This process causes energy losses, which takes the form of heat. The total energy loss comprises of two components:

- *Current-independent losses*: they are practically constant, this means they also occur at no-load.
 - core losses caused by polarity changes and eddy currents
 - mechanical losses caused by friction and aeration
- *Current-dependent losses*: they increase with load, i.e. with increased current.
 - I^2R losses in the stator
 - I^2R losses in the rotor

The power loss increases approximately in proportion to the square of the current . The latter is almost proportional to the motor's slip. According to **Figure 2.2.1**, for a stalled , static rotor, the maximum starting current in the stator is $4...8 I_n$. The total input power is transformed into heat. If the rotor remains stalled, the temperature of the stator and rotor winding increases considerably, as part of the heat can only flow into the motor casing after a delay. If the motor is not switched off in time, the stator and rotor winding can burn out

The heat losses generated reduce with increased speed. After run-up, the temperature increases further in an e-function, as shown in **Figure 2.2.2**, until it reaches final temperature level. For a higher load, the final temperature will be correspondingly higher.

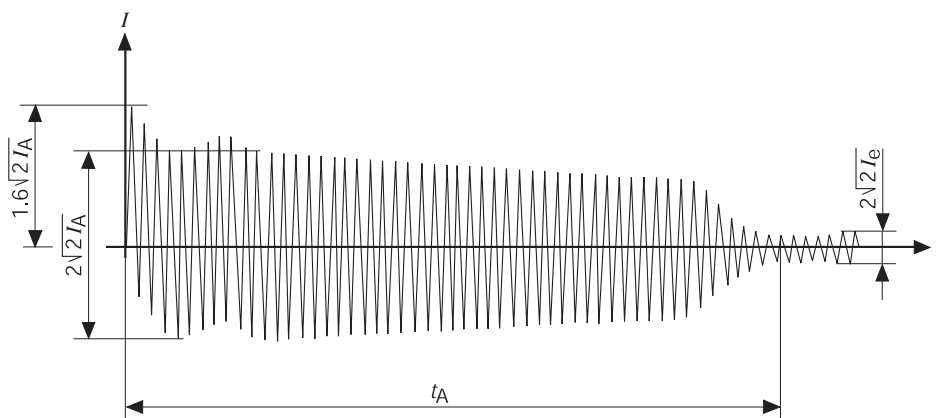

Fig. 2.2.1 Squirrel-cage motor started direct on line (DOL).
 During starting time t_A , a high motor starting current I_A flows. It does not cause excessive heating if the starting time remains below the limit specified by the motor manufacturer, which is usually 10 sec. The short-term, unbalanced starting current peak can be ignored.

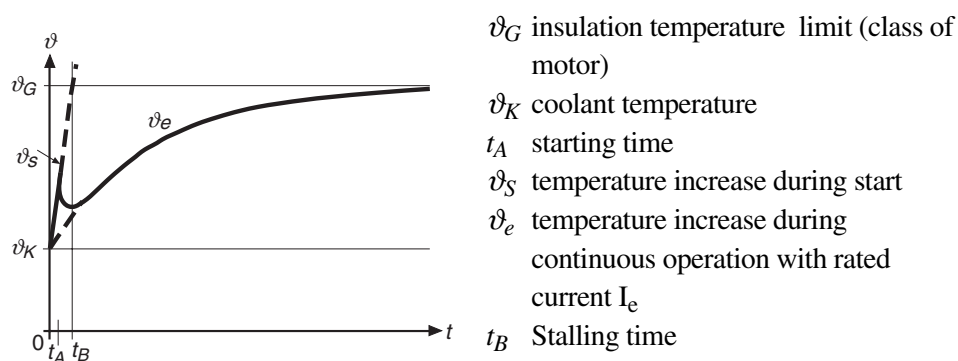

Fig. 2.2.2 Temperature increase in the motor winding
 Due to the high starting current I_A , the winding's temperature increases during starting time t_A very quickly. After the start, the temperature drops temporarily, as heat is transferred to the motor body. If the rotor remains stalled, the windings reach their temperature limits very quickly.

Electrical motors are thermally non-homogenous systems. The windings, stator iron and rotor have a different heat capacity and heat conductivity. After start and during load changes, a temperature compensation takes place between the different machine parts. The heat flows from the hot winding to the cooler iron until a temperature balance has been achieved.

2.1.2 Limiting temperature and insulation classes

The limiting temperatures of the windings and, thus the permissible motor load are above all determined by the winding insulation. The IEC-recommendations for electrical machines (IEC 34-1 and IEC 85), as well as Regulation VDE 0530 Part 1, have been listed in **Table 2.3.1**. A difference is made between:

- *Max. coolant temperature*: the motor can achieve its rated power at this temperature.
- *Limiting temperature in K* is the average value from resistance measurements. The winding temperature is the sum of the coolant temperature and the winding warm-up. If the coolant temperature is below 40 °C, the motor load can be increased. If it exceeds 40 °C, the load has to be reduced.
- *Highest permissible permanent temperature in °C* for the hottest winding spot.

Insulation class	Max. coolant temp. in °C	Temp. over limit in K	Highest permissible constant temp. in °C
E	40	75	120
B	40	80	130
F	40	105	155
H	40	125	180

Tab. 2.3.1 Insulation material classes and highest permissible constant winding temperatur

The highest permissible constant temperature of individual insulation materials comprises of coolant temperature, temperature over limit and a heating-up tolerance. The latter is a safety factor, since the temperature measurement by ohmic resistance does not establish the hottest winding spot.

For very high ambient temperatures, motors with specially heat-resistant insulation are produced. These machines can also achieve their rated power at high coolant temperatures.

By far the most widespread cooling type is self-ventilation with ambient air. By means of a shaft-mounted fan, self-cooled motors guide an airstream over the housing surface. This means that the coolant - air - has the same temperature as the area immediately surrounding the motor. The cooling power depends on the motor speed.

Due to their simple structure (no insulation), ordinary squirrel-cage motor rotors do not have a critical temperature. Therefore, they are permitted to reach a higher temperature constantly.

Problems can occur during the starting of medium voltage and larger low voltage motors, since the value of the losses can limit the starting time. The starting time and the permissible stalling time are therefore limited by the rotor's heat capacity. These motors are called "rotor critical" motors. The high temperature increase can lead to mechanical tensions and result in an de-soldering of rotor rods.

For motors with protection type "increased protection - EEx e", the increased temperature can serve as an ignition source.

2.1.3 Insulation ageing

If the temperature limit is adhered to, the winding life time for all insulation classes can be estimated at 100,000 h. This corresponds to approximately 12 year of continuous operation at rated power. Insulation ageing is a chemical process, which is highly temperature-dependent as shown in **Fig. 2.4.1**. Due to heating up, part of the insulation material evaporates, which leads to an increasing porosity and, as a result of this, a decreased voltage resistance. The following rule applies: if the operating temperature exceeds the highest permissible temperature by 10K, the life span reduces by half. Short-term excessively high temperatures do not have a considerable impact on a motor's life span. The continuous operating temperature, however, must not exceed the highest permissible value.

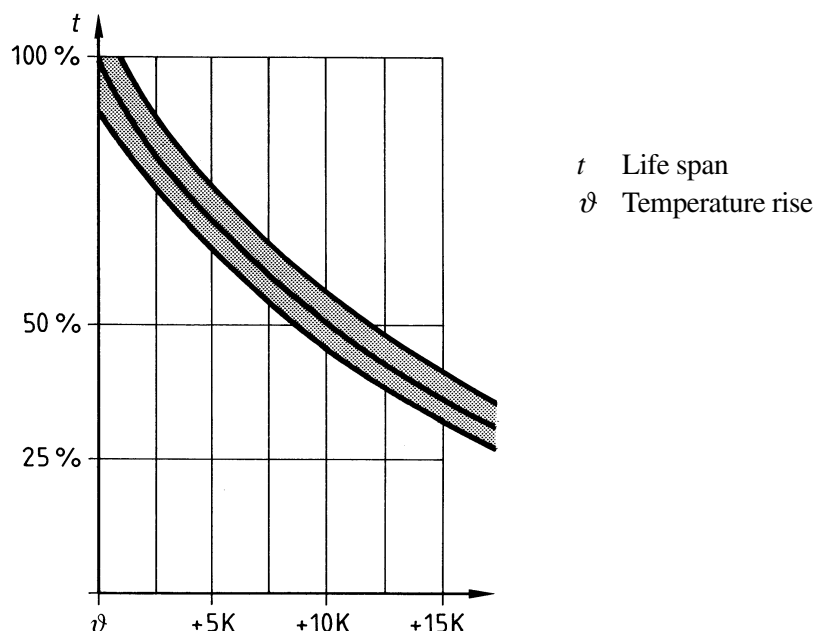

Figure 2.4.1 Reduction of an average motor winding life span due to excessively high temperature.

Modern design methods take the motor's overload-situations into consideration. This makes it possible to make full use of the life cycle reserve. This is called life-cycle oriented design, which has the aim to enable motor operation for as long as the motor has to operate for economic reasons.

2.1.4 Response limits

In order to guarantee the protection of standard motors, the IEC has established response limits for time-delayed overload-relays.

Values according to IEC 947-4-1 apply to temperature-compensated, balanced pole load overload relays adjusted to the rated operating current.

Figure 2.5.1 and **Table 2.5.1**.

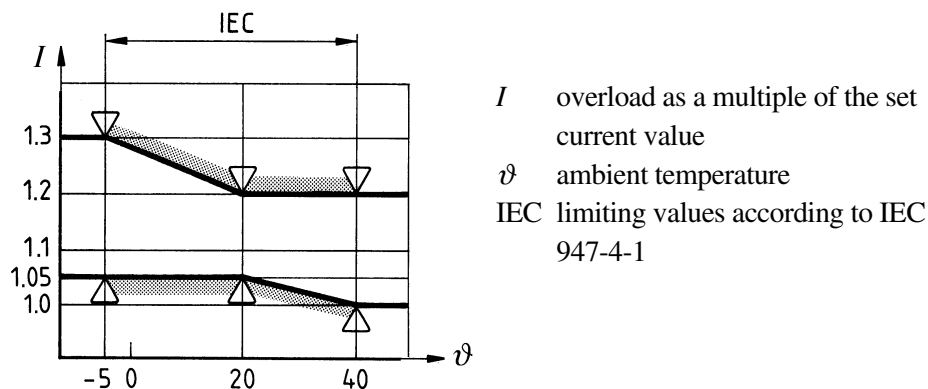

Figure 2.5.1 Current multiple limiting-values for temperature-compensated overload-relays acc. to IEC 947-4-1.

Function		should not respond from cold	to respond after following current increase	to respond from warm	to respond from cold
Multiple of the set current value		1.05	1.2	1.5	7.2
Response time acc. to response class:	10 A	≥ 2 h	< 2 h	< 2 min	2...10 s
	10	≥ 2 h	< 2 h	< 4 min.	4...10 s
	20	≥ 2 h	< 2 h	< 8 min.	6...20 s
	30	≥ 2 h	< 2 h	< 12 min.	9...30 s

Tab. 2.5.1 Response limits at +20 °C and balanced pole load for ambient temperature-compensated, thermal, overload relays acc. to IEC 947-4-1.

For a two-pole load on three-pole thermal overload-relays (e.g., for failure of a phase), the response limits listed in **Table 2.6.1** apply.

2.1.5 Phase failure

Type of thermal overload-relay	Multiple of set current value		Ambient environment temperature
	response $t > 2$ h, based on cold condition of relay	response $t \leq 2$ h	
ambient temperature compensated not sensitive to phase failure	3 Poles 1.0	2 Poles 1.32 1 Poles 0	+ 20 °C
not ambient temperature compensated not sensitive to phase failure	3 Poles 1.0	2 Poles 1.25 1 Poles 0	+ 40 °C
ambient temperature compensated sensitive to phase failure	2 Poles 1.0 1 Pole 0.9	2 Poles 1.15 1 Pole 0	+ 20 °C

Tab. 2.6.1 Response limits for three-pole thermal overload-relays with two-pole load only.

2.1.5 Phase failure

A phase failure is an interruption of a single conductor. The motor then continues running with two phases and can suffer damage. The cause is, for example, blown fuse. Small to medium-sized motors are mostly stator-critical - this means that only the stator can be damaged. It has to be differentiated between:

- *Motors in star connection:* these motors are not put at risk by a phase failure. As shown in **Fig. 2.7.1**, the currents in the motor windings, during disturbed and undisturbed operation at the failure of a single conductor, equal the currents in the other two. Due to the increasing current, a higher power loss occurs in both live windings. On the whole, the motor is running cool, since the third cold winding causes a temperature compensation. In case of an over-current, a protective current detector trips in time. Small to medium-sized (stator-critical) motors in star connection are usually not put at risk during a phase failure.
- *Motors in delta connection:* In delta connection, the phase currents in undisturbed operation are lower by a factor $1/\sqrt{3}$ than the currents in the windings $I_{STR} = 0.58 I_n$. During the failure of a phase, the current increases for electromagnetic reasons by approximately 50%, as shown in **Fig. 2.7.2**. In the other two windings, which are now switched in series, the current falls to

approximately 67%. This phenomenon occurs because the motor keeps the power transmitted to the shaft practically constant. The absolute current increase in the windings and in both intact phases depends on the load applied.

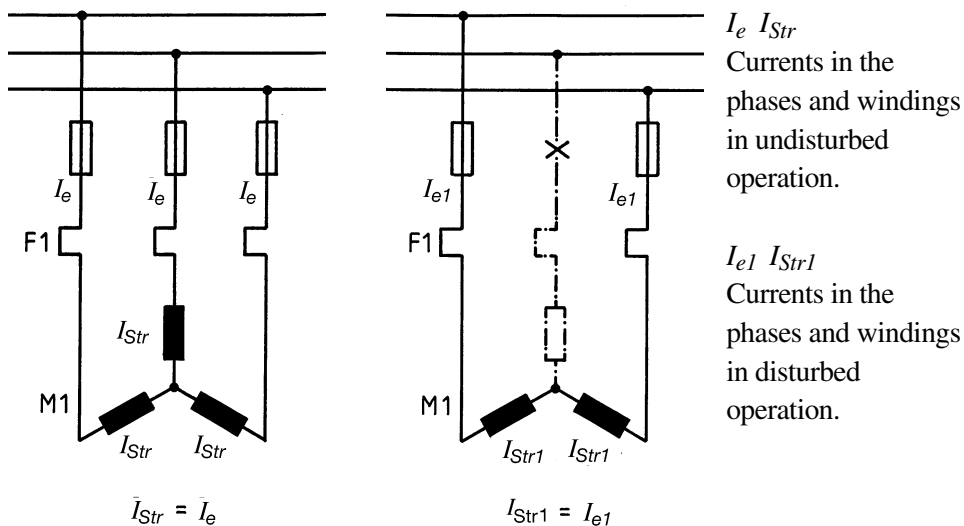

Fig. 2.7.1 Phase failure of a motor in star connection. Current flow in undisturbed and disturbed operation.

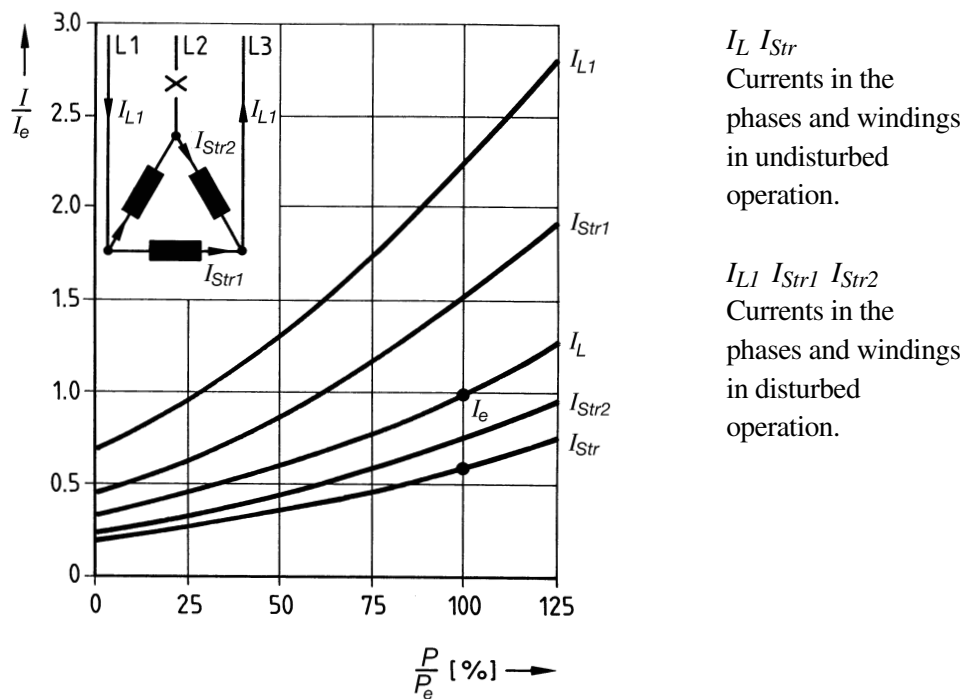

Fig. 2.7.2 Phase failure of a motor in delta connection. Current flow during undisturbed and disturbed operation as function of the load.

Since the currents in the windings are not equal, they do not warm up equally either. Since heat is exchanged between individual windings and between windings and the iron body, the warming up of the stator is proportional to the sum of all losses in all windings. In general, the following applies for motors with an output of:

- $P_e \leq 10kW$: they do not require a special phase failure protection, as long as the two-phase trip current is $\leq 1.25 I_e$. In this case, the warming up is, at the most equal, to the warming up during a symmetrical, three-phase load.
- $P_e \geq 10 kW$: for these motors, a motor protector with phase failure protection or a quick-response electronic protector is recommended. Besides electrical protection, the fast cut-out also contributes to reduced stress on the bearings. Many companies and electricity company's factory regulations demand phase-failure sensitive motor protection mainly for bigger drives, or for systems with an increased safety requirement.

For a single-phase feed of the stator, the rotor losses are considerably higher compared to a symmetrical feed. This can represent an additional danger, especially for rotor-critical motors.

2.1.6 Asymmetry in the network

The voltage between lines, as well as the phase voltage in the induction net, are not exactly the same. Causes can be, for example:

- very long mains supply lines
- defective contacts on power-circuit breakers and contactors
- loose terminal connections

IEC and NEMA define the voltage asymmetry like this:

$$\Delta U (\%) = \frac{\text{Maximum deviation from the average of the phase voltages} \times 100}{\text{average of phase voltages}}$$

The current asymmetry of the winding currents resulting from the voltage deviations amounts to 6...10fold of the voltage asymmetry and causes an additional heating up and reduction of the motor's life span. **Fig. 2.9.1** shows the reduction factors for the motor output according to IEC and NEMA.

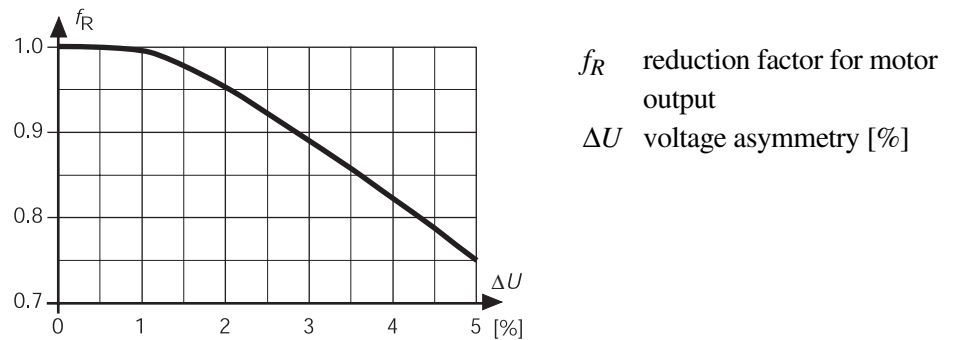

Fig. 2.9.1 Power reduction as a result of voltage asymmetry.

2.1.7 Earth fault

Insulation damage usually results from high voltage surges and often leads to shorts against earthed machine parts. Sources of these discharges are lightning strikes, network switches, capacitor discharges and the operation of power engineering systems.

2.1.8 Short circuit

A difference is made between single-pole shorts against earth and two- and three-pole short circuits with and without earth contact. The main causes for these short circuits are insulation damage and mechanical damage. The currents depend on the circuit's impedance and can reach high values. As the duration of the short circuit increases, the material damage also increases. Therefore, short circuits should be detected quickly and switched off.

Motor protection

3 The system's protection requirements

3.1 Stalling

An excessive load torque or mechanical damage can cause a drive to be stalled. It is advisable to disconnect the drive affected as quickly as possible from the network. By doing this, any unnecessary mechanical and thermal strain on the motor and power transmission elements is avoided. In general, the number of possible accidents can also be reduced.

3.2 Underload

Dangers from underload and a correspondingly low current take-in are possible when motors are cooled by the pumped medium itself. Problems can, for example, occur for ventilators or underwater pumps by a lack of, or insufficient, pumping volume due to blocked filters or closed valves. The drives can overheat despite being underloaded. Such machines can usually be found in inaccessible locations, like pumps in boreholes, which can result in costly repairs when damage occurs. Occurrence of an underload during a low current can also point to a mechanical fault. Examples for this are defective couplings, broken shafts, torn transport belts, damaged ventilator blades, etc. Such underload situations do not represent a danger to the motor, they do, however, cause plant down times and can lead to system damage. Quick fault detection helps reduce down times and possible accidents.

3.3 Incorrect rotation

Switching on a drive with the incorrect rotation can severely damage a system and is often linked to high accident probability. For mobile systems, such as construction machines, cooling transporters etc., the incorrect rotation has to be expected following repairs or work carried out on the electrical distribution network. Switching on these drives, which have the incorrect rotation, has to be avoided.

3.4 Motors in explosion-risk areas

3.4.1 Ignition protection type and increased safety EEx e

Under certain conditions, mixtures of ignitable gases and vapours and air can be ignited by sparks or high temperatures. The ignition temperature depends on the mixture's chemical composition and the mixing ratio.

The ignition of a mixture, which could explode, can be avoided for motors if it is ensured that the maximum temperature of the hottest spot lies below the lowest critical ignition temperature for that area. The limiting temperature of the winding insulation must, of course, not be exceeded.

3.4.2 Significance of time t_E

The time t_E is, according to **Figure 3.2.1**, the period of time which passes when the motor is warmed up from the rated operational temperature to the permissible limiting temperature. It is calculated for the most unfavourable case, i.e. for a stalled rotor and the highest permissible ambient temperature. Therefore, a motor protection device has to switch off the motor during starting current I_A (highest value for stalled rotor) within time t_E . This means that the motor does not reach the critical temperature.

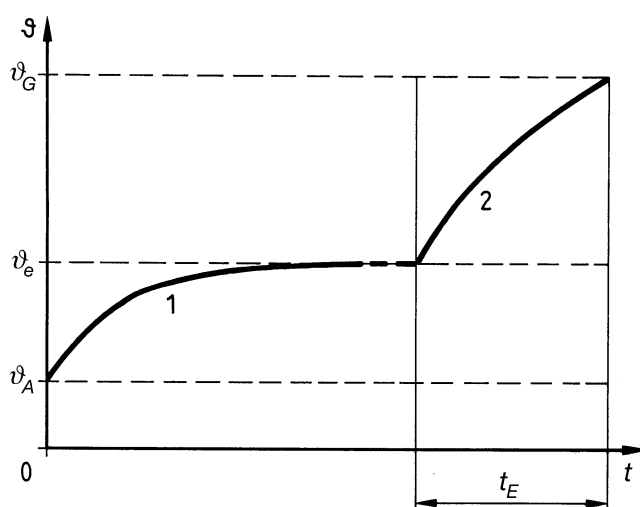

Figure 3.2.1 Definition of time t_E , within which a motor with a stalled rotor warms up from its rated operational temperature to its limiting temperature.

- ϑ Temperature
- ϑ_A The motor's highest permissible ambient temperature
- ϑ_e Rated operational temperature
- ϑ_G Limiting temperature
- t Time
- 1 Temperature Rise during rated operation
- 2 Temperature Rise with stalled motor

For countries with a general test requirement, the time/current curve is automatically included. Only devices which have been checked in this way can be used in these countries to protect EEx e motors.

4 Protection measures

For motor temperature control, the following two methods, which complement each other, are used:

- *Temperature measurement with sensors installed in the stator winding:* the sensor measures the temperature directly in front of the motor winding, but only at the location where it has been fitted. In addition to this, the sensor's thermal delay, often exceeds 10s, this has to be considered.

The following are not measured:

- rotor overload
 - phase failure
 - asymmetry
 - short circuit
 - earth fault
- *Current measurement in supply line:* a current measurement in the supply line is useful if the motor's temperature increase is known as a function of the motor current. The protection devices can be adjusted in accordance with the rated operating current and for brief overload situations.

Motor protection

5. Temperature-dependent protection measures

5.1 Application problems

5.1.1 Applications

The temperature sensors are installed in the stator winding shoulder. Therefore, they measure the motor's critical temperature directly. Temperature sensors are mainly used under the following operating conditions:

- changing load
- start - stop - operation
- countercurrent braking
- high ambient temperature
- poor cooling, for example, in dusty surroundings
- speed-controlled motors.

For different applications, the temperature sensor alone provides insufficient or even no protection at all. In these cases, additional current-measuring protectors are used. This is necessary for:

- rotor-critical motors
- protection in case of
 - earth failure
 - short circuit
 - a locked rotor
 - Motors with low thermal inertia
- quick reaction in case of phase failure and asymmetry.

5.1.2 Thermal inertia

For motors with low thermal inertia like thermally encapsulated refrigeration motors or underwater pump drives, the thermal delay between winding and sensor can prove critical. The interaction time is, depending on the type of sensor and its installation into the winding, within 10s.

Fast temperature changes represent a protection problem. During continuous operation, winding and sensor have practically the same temperature. During start or large load changes as is the case, for example, with a locked rotor, the winding temperature increases very quickly. The sensor temperature follows in line with the interaction time constant shown in **Figure 5.2.1**.

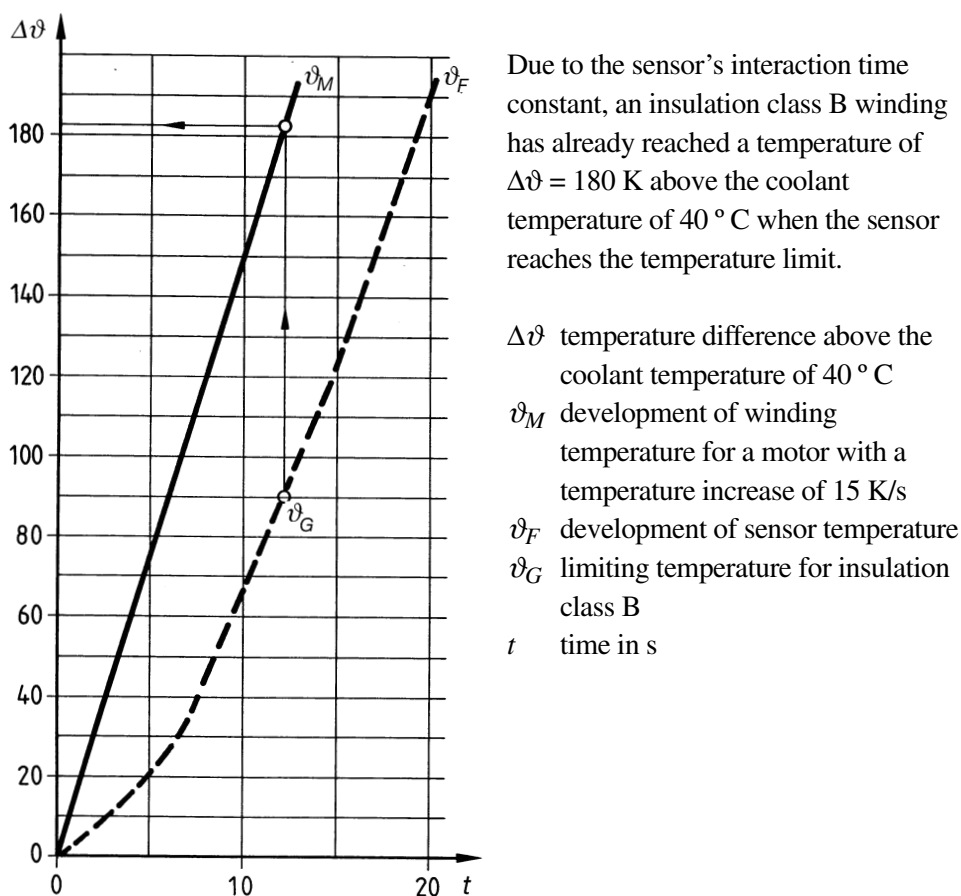

Fig. 5.2.1 Thermal delay of a PTC sensor integrated into the stator winding.

For example, during the stalling of an underwater motor, the current density in the stator winding can reach up to 50 A/mm^2 . In this case, the winding temperature increases rapidly at approximately 15 K/s . When the sensor with an interaction time constant of 8 s reaches the permissible temperature limit for insulation class B, the winding temperature has already reached more than 180 K above the coolant temperature of 40°C . The motor can be at risk.

5.2 Bimetallic sensors in the winding

Bimetallic sensors consist of two metals with different thermal expansion coefficients rolled on top of each other. If they are warmed up, they expand unevenly and can trigger a switch contact. They have the advantage that the control voltage can, in principle, be directly applied to the switch, which makes a special tripping mechanism unnecessary. The following disadvantages, however, restrict their application:

- long thermal delay
- restricted accuracy. The tripping temperature can be affected by careless fitting.
- large size compared to modern sensors.

5.3 PTC-sensors

The sensor most commonly used in low voltage motors is the thermistor with positive temperature coefficient (PTC). These PTC-resistors are also referred to as thermistors. The miniaturised sensors (**Figure 5.3.1**) have a low resistance below the rated response temperature, and increase their resistance in the rated response temperatures range, as shown in **Figure 5.4.1**, by several ranges. This resistance change is evaluated by means of a tripping device. The rated response temperature is defined by the PTC - sensor and thus is independent of the tripping device.

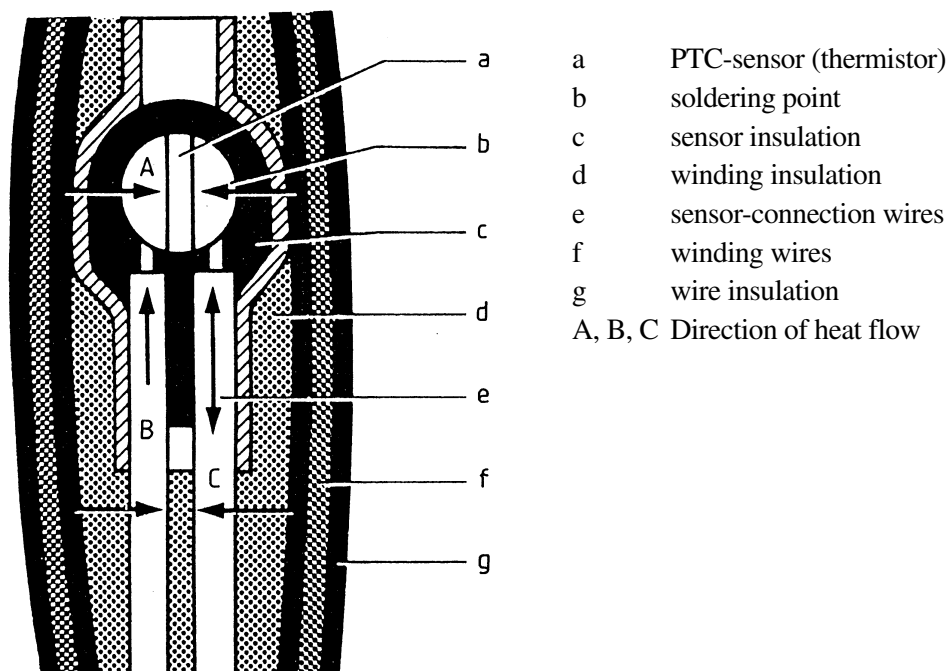

Fig. 5.3.1 Cross-section of a PTC sensor and a low voltage motor winding

The sensors are installed into the motor's winding shoulder from the discharge airside, and the rated response temperature TNF is allocated to the corresponding insulation class. The sensor's response can be used to switch off the motor switch or for detection. If a warning is to occur before the critical temperature has been reached, further sensors with a lower rated response temperature have to be installed.

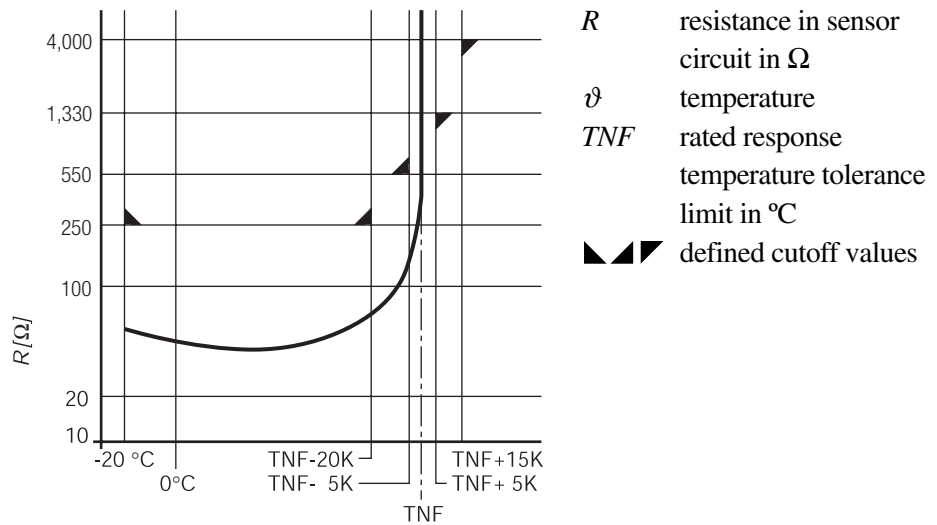

Fig. 5.4.1 Characteristic resistance-temperature curve of a PTC-sensor in line with IEC 34-11-2.

5.4 Linear temperature sensors

Pt 100 platinum sensors are normally used as linear temperature sensors. The resistance value changes in proportion to the temperature. As shown in Figure 5.4.2, at 0 °C Pt 100-sensors have a resistance of 100Ω. They are predominantly used in large motors. Medium-voltage motors usually have Pt 100 - sensors incorporated as standard.

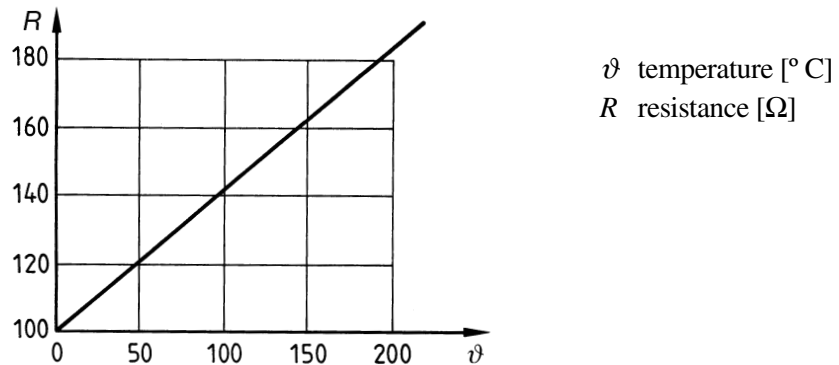

Figure 5.4.2 Characteristic resistance curve of a Pt 100-sensor.

Contrary to the PTC-sensor, whose rated response temperature is determined by the sensor, the Pt 100-sensor's response temperature can be freely adjusted on the tripping device. In addition to this, every possible temperature value can be picked up for pre-warning, restart locking or load control. Ni 100 -, Ni 120 - and Cu 10 - sensors are rarely used.

6 Current-dependent protection

6.1 Function

The motor's current consumption is a measurement of its temperature rise. Since the temperature in the stator winding or the rotor body is not measured, this connection only applies if the following marginal conditions are adhered to:

- the motor's rated load refers to the maximum coolant temperature of 40 °C.
- temporary overloads, for example, during start, have to be tolerated by the overload as shown in **Figure 6.1.1**.

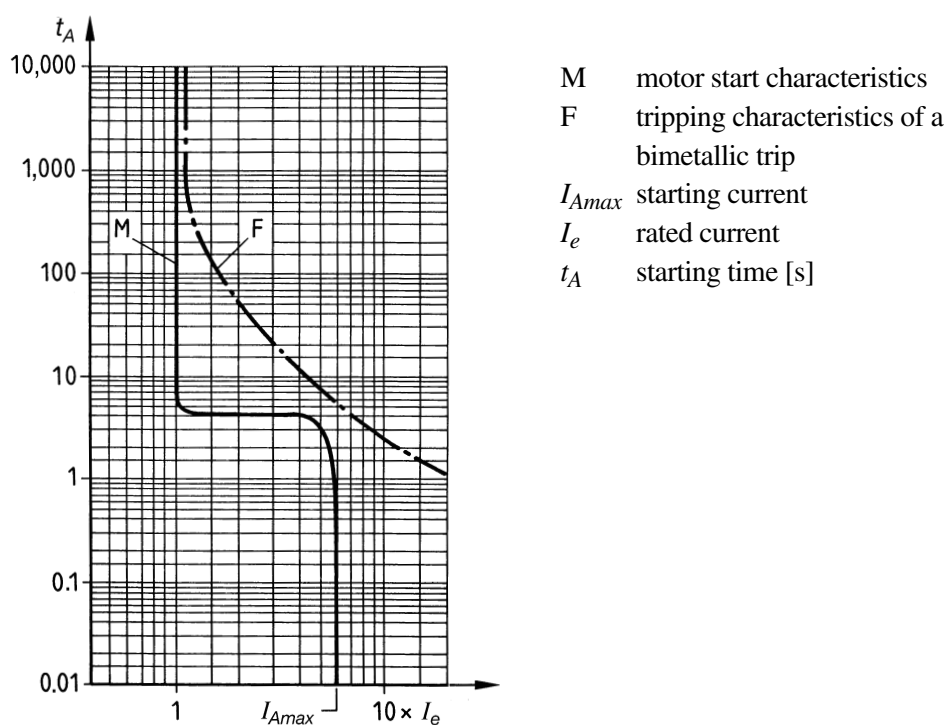

Fig. 6.1.1 Motor overloads must permit the motor to start. The characteristic device curve F must always stay above the characteristic motor curve M

For protection systems, which detect currents, the problems and restrictions discussed for temperature sensors do not apply.

6.2 Device characteristics

6.2.1 Stationary operation

During stationary operation, exceeding the limiting temperature as shown in **Fig. 6.2.1** can also be prevented by means of a simple protective device whose warm-up curves do not correspond to those of the motor. It is a precondition is that the protector is thermally equally as fast or faster than the motor.

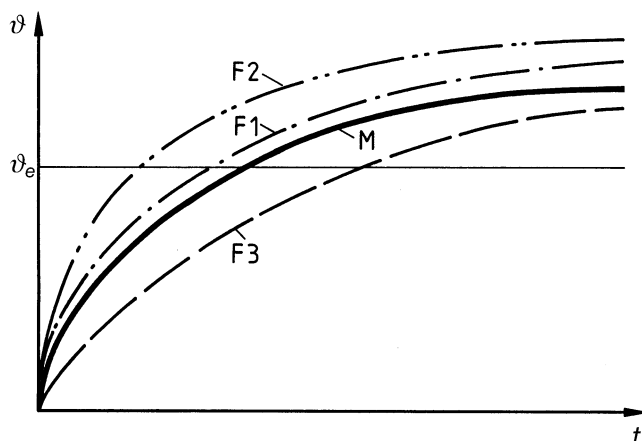

Fig. 6.2.1 Temperature Rise characteristics of a motor and thermal protector for a low overload during continuous operation.

- M thermal motor curve
- F1, F2 fast motor protection devices: motor is protected against overload
- F3 slow motor protection device: motor can heat up to impermissible value during overload
- ϑ temperature
- ϑ_{Ie} temperature during rated operation
- t time

- *Tripping device faster than motor temperature riser curve:* the motor is protected against an overload. The protection device trips too early and prevents full use of the motor.
- *Tripping device slower than motor temperature rise curve:* The motor can heat up to an impermissible value.

By means of high-quality motor protection devices (**chapter 6.6**), the motor temperature rise curve can be projected accurately. Despite maximum use, the motor is safely protected.

6.2.2 Intermittent operation

During constant load or one-off motor warm-up, the thermal conditions are relatively easy. During changing operating conditions, however, e.g., during periodic duty, it is very important that the motor and the protector share the same transient condition. **Figure 6.3.1** shows how the different characteristic curves diverge. During intermittent operation, the winding's temperature, compared to that of the iron, changes rather drastically. For cycle times under 5...10 min the latter remains practically constant. In addition to this, the cooling conditions of self-ventilated motors during run and standstill differ quite considerably. The cooling time constant is approximately 2...5 times longer than the warming-up time constant. Bimetallic and simple electronic protective devices do not take this fact into consideration.

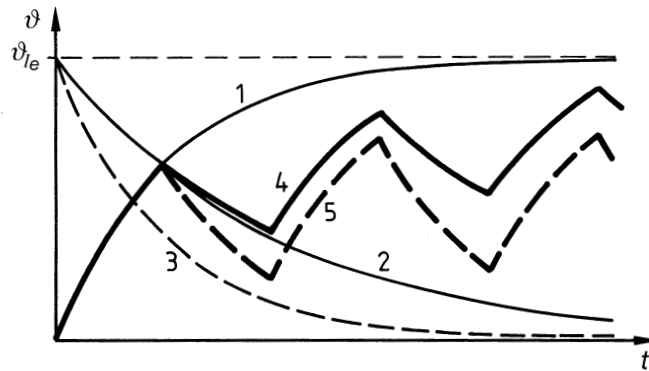

Figure 6.3.1 Temperature Rise and cooling characteristics of motor and thermal relay during intermittent load

- 1 Temperature Rise characteristics of motor and thermal relay
- 2 cooling characteristics of motor
- 3 cooling characteristics of a thermal relay, without taking different cooling conditions during run and standstill into consideration
- 4 development of winding temperature in the motor
- 5 development of winding temperature projected by thermal relay
- θ_{Te} temperature during rated operation
- t time

The transient behaviour of different motors is not the same. Nevertheless, protective devices should project the motor's temperature behaviour as accurately as possible. In most cases, a compromise is necessary, resulting in a slightly overprotected motor.

Also during intermittent operation, the electronic protection devices mentioned in **Chapter 6.6** can allow maximum motor use.

6.3 Bimetallic - Protection principle

6.3.1 Function

Thermally delayed overload-relays and the overload protection of most power circuit breakers use bimetallic strips, which are heated by the motor current. As shown in **Figure 6.4.1**, the bimetallic strips trigger an auxiliary contact via a trip bar, which interrupts the motor contactor's coil circuit. For power circuit breakers direct tripping occurs. The following heating types can be distinguished according to **Figure 6.4.2**:

- *Direct heating*: the heating current of approximately 20...70 A flows directly through the bimetallic strip. Lower currents are not permissible, since their heating capacity ($P_v = I^2 R$) is insufficient for deflection.
- *Indirect heating*: the current does not flow through the bimetallic strip but through a heater winding which is coiled around the bimetallic strip. They are suitable for currents of approximately 0.1...20 A.

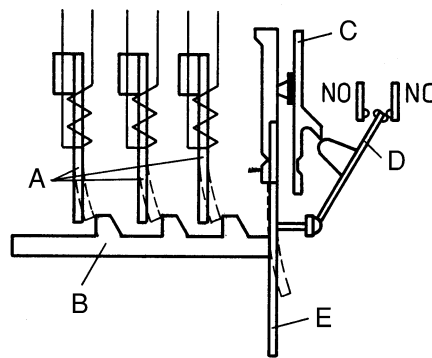

- A indirectly heated bimetals
- B trip gate
- C trip lever
- D moved contact
- E compensation bimetal

Fig. 6.4.1 Functional principle of a three-pole, thermally delayed thermal relay with temperature compensation. In accordance with IEC, the temperature compensation takes place between $-5\text{ }^{\circ}\text{C}$ $+40\text{ }^{\circ}\text{C}$.

- *Transformer heating:* the motor current ($> 60\text{ A}$) flows through a transformer's primary winding. The bimetal's heating winding is connected at the secondary side. In case of a short circuit, the bimetallic relay is practically fully protected.

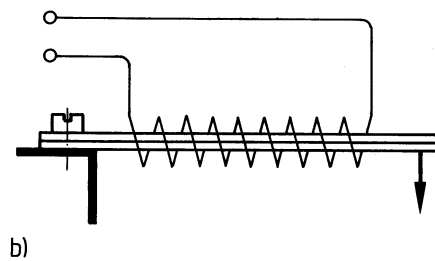
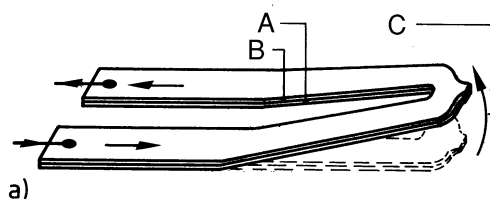

- A high expansion alloy
- B low expansion alloy
- C deformation caused by heating up
- D anchor

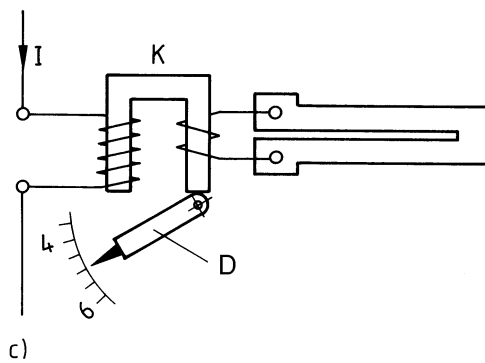

Fig. 6.4.2 Properties of heated bimetals.

- a direct heating
- b indirect heating
- c transformer heating (transducer relay)

Thermal relays are mostly temperature-compensated. An additional compensation bimetal in the power transmission path from the current-bimetal to the trip contact prevents the relay's tripping characteristics from changing - as a result of the ambient temperature which acc. to the IEC lies between $-5...+40\text{ }^{\circ}\text{C}$, and adversely affecting the protected object. Since the permissible motor load reduces with increasing coolant temperature, the relays are often slightly under-compensated for safety reasons.

During the start followed by constant load, the thermal relay protects the motor without any problems. During intermittent operation with high switch frequency and changing load, however, motor protection is only insufficient, since the thermal relay can only approximately reproduce the motor's thermal behaviour. During frequent starts in intermittent operation, the bimetal's time constant, which is considerably shorter compared to the motor's, causes a premature trip. This means that the motor's thermal capacity cannot be fully used. In addition to this, the thermal relay's cooling time constant is shorter. This means that, during intermittent operation, the difference between the motor's temperature and the thermal relay's simulation increases constantly. **Fig. 6.3.1.**

6.3.2 Short circuit resistance

For thermal reasons, the short circuit resistance of directly heated thermal relays is higher than for indirectly heated relays. During high rated currents, thermal relays are therefore operated via current transformers. They provide short circuit resistance up to the highest currents. The following short circuit resistance values apply for the current I_{eF} , adjusted at the thermal relay:

- indirectly heated thermal relays up to $16 I_{eF}$ max
- directly heated thermal relays up to $30 I_{eF}$ max
- current transformer thermal relays up to $50 I_{eF}$ max

6.3.3 Single-phase operation

The power required for tripping the switch mechanism can only be generated by three bimetallic strips together. The three bimetallic relays have to be switched in series, as shown in **Figure 6.6.1**, to ensure that a current also flows through them during single-phase operation.

6.3.4 Phase failure

Motors in star connection are not thermally at risk if a phase fails. For motors in delta connection, the following differences have to be made between:

- *rated output $P_e \leq 10\text{ kW}$* : the thermal relay's single-phase starting current should amount to $\leq 1.25 I_e$

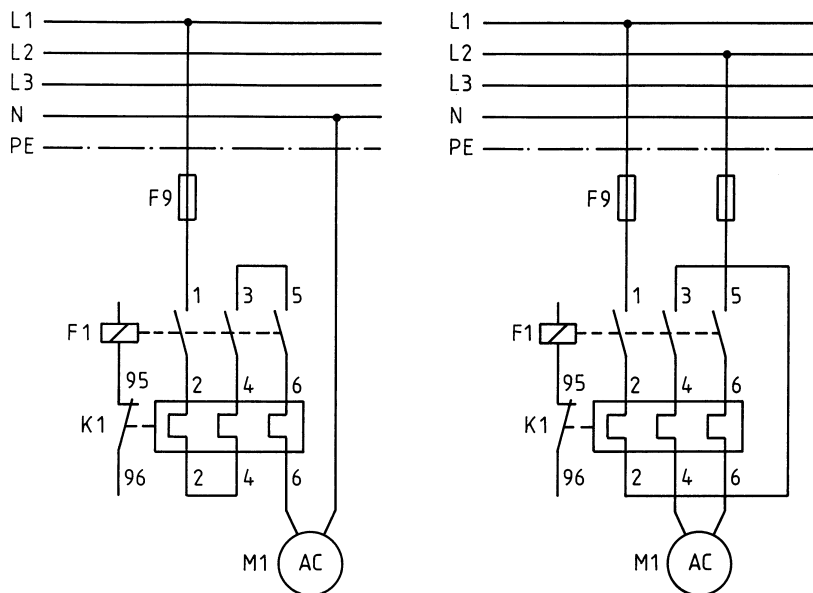
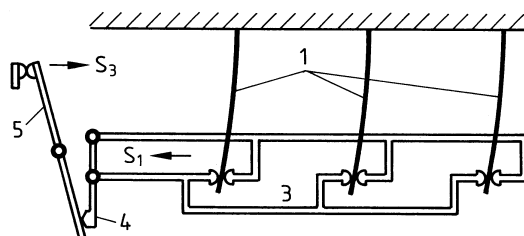

Fig. 6.6.1 Series circuit of thermal relay bimetals during single-phase operation.

- rated output $P_e \geq 10 \text{ kW}$: the motor protectors should be equipped with a differential trigger.

The resource regulations of various industries require differential triggers, for example the chemical, petrochemical and gas industries.



Tripping during a three-phase overload

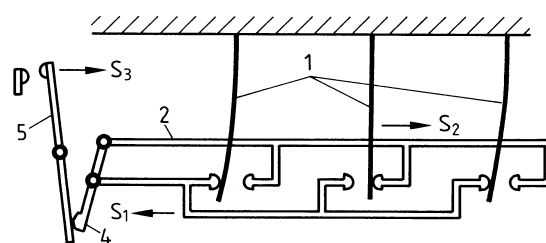

Tripping during failure of a phase with unheated, medium bimetal

Fig. 6.6.2 Differential tripping principle for thermal relays

- | | |
|--|--|
| 1 bimetallic strip | 4 differential lever |
| 2 failure gate | 5 tripping contact (spring-loaded contact) |
| 3 overload gate | S_1 tripping motion during overload |
| S_2 tripping motion during phase failure | |
| S_3 opening of tripping contact | |

As shown in **Figure 6.6.2**, a double gate arrangement consisting of a failure gate and an overload gate forms the basis of differential tripping. During phase failure, the dead, cooling bimetal moves the failure gate in the opposite direction to the overload gate. This reciprocal motion is transformed into an additional tripping motion by a differential lever.

During phase failure, this double gate arrangement causes tripping at 85% of the three-phase tripping current. This refers to the current flowing through the thermal relay. When the motors are switched in delta and during phase failure, the currents in the thermal relay and the motor windings differ. The current distribution in the motor is also not constant but load-dependent.

Fig. 6.7.1 shows the typical characteristic tripping curve of a thermal relay with and without differential trigger for cold or warm condition.

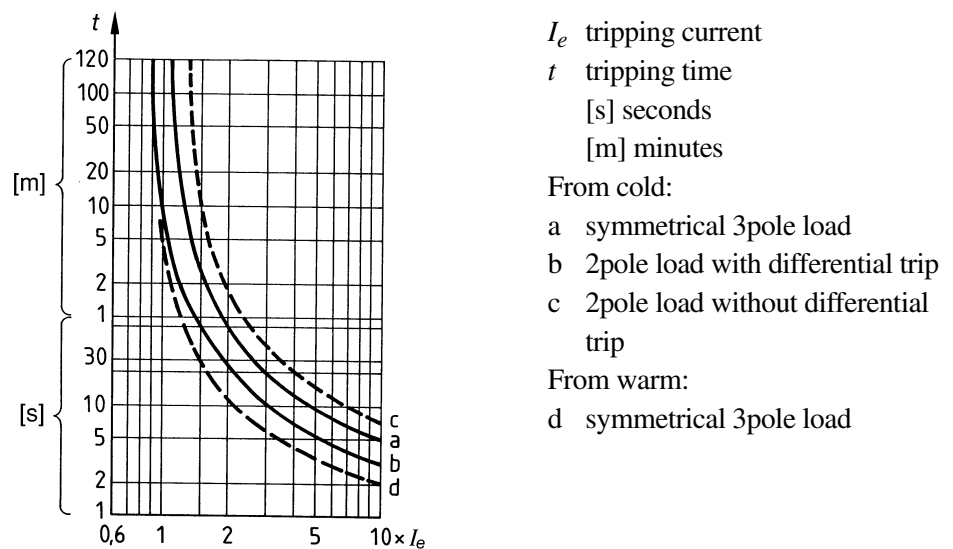

Fig. 6.7.1 Typical characteristic tripping curve of a thermal relay.

6.3.5 Recovery time

After tripping, thermal relays require a certain period of time for the bimetal strips to cool down again. This period of time is termed recovery time. They can be reset only after this time has expired.

The recovery time depends on the thermal relay's tripping curve and the size of the current leading to tripping. **Figure 6.8.1** shows the average values for thermal relays recovery time. It can be seen that, following tripping with a 4fold set current, the recovery time is approximately 35 s.

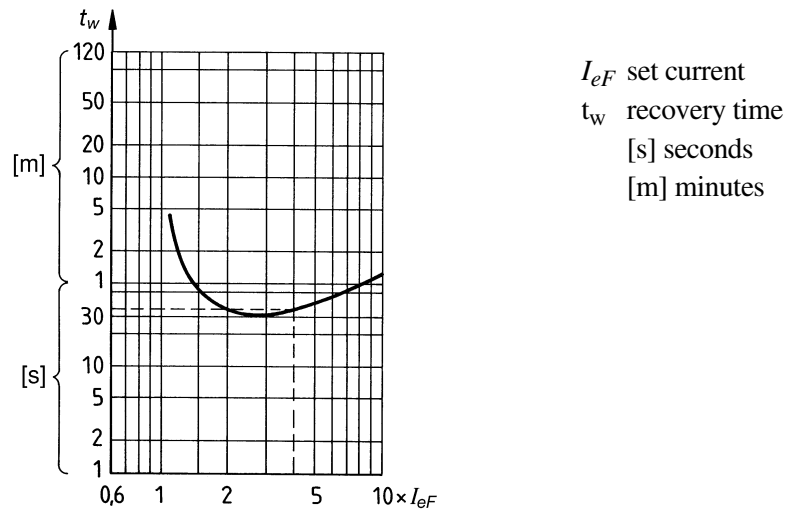

Fig. 6.8.1 Guidance values for the recovery time of thermal relays

The recovery time also serves the purpose of enabling the motor to cool down during this operational pause. This period of time is, however, in most cases insufficient to allow a re-start.

6.3.6 Current setting

In general, the thermal relay has to be set to the rated current I_e . The scale dials of most protectors have one current range for direct start and another for star-delta start. The latter already has a factor of $1/\sqrt{3}$ built in.

If the coolant temperature exceeds 40 °C, the motor power has to be reduced and the current setting has to be adapted to the thermal relay. If the motor manufacturer does not advise otherwise, **Table 6.8.1.** applies.

Coolant temperature °C	30	35	40	45	50	55	60
Correcting factor I_e	1.08	1.04	1	0.95	0.9	0.85	0.8

Tab. 6.8.1 Guidance values for correcting current setting factors on thermal relays for motors with deviating coolant temperature

For installation heights which are over 1000 meters above sea-level, the permissible motor loads decrease and, therefore, so do the thermal relay settings. If the motor manufacturer does not advise otherwise, **Table 6.9.1.** comes into effect. Should deviating coolant temperatures occur at the same time as installation at great heights, the product of both factors has to be considered when setting the current at the thermal relay.

Installation height meters above sea level	Factor for correction of rated output
≤ 1000	1.00
≥ 1500	0.97
2000	0.94
2500	0.90
3000	0.86
3500	0.82

Tab. 6.9.1 Guidance values for rated output correction for a deviation in installation height.

6.3.7 Trip Free Mechanism

“Trip Free” is required by the IEC and various national regulations. Tripping must also function if the reset key or the 0-key are pressed at the same time. The tripping mechanism is reset by pressing the reset key once more.

With many thermal relays, the tripping mechanism also functions for automatic reset with blocked reset key. It is only possible to switch on again after the reset key has been pressed again.

6.4 Motor protection during heavy load start

A motor’s starting current $I_A \approx 4...8 I_e$ is not dependent on the load but on the motor design. The acceleration time t_A however, is load-dependent. In accordance with Fig. 6.9.1, the term heavy load start is used if the acceleration time is dependent on the starting current and amounts to a few seconds. Under these conditions, a standard-thermal relay is placed under too much thermal strain and trips in most cases.

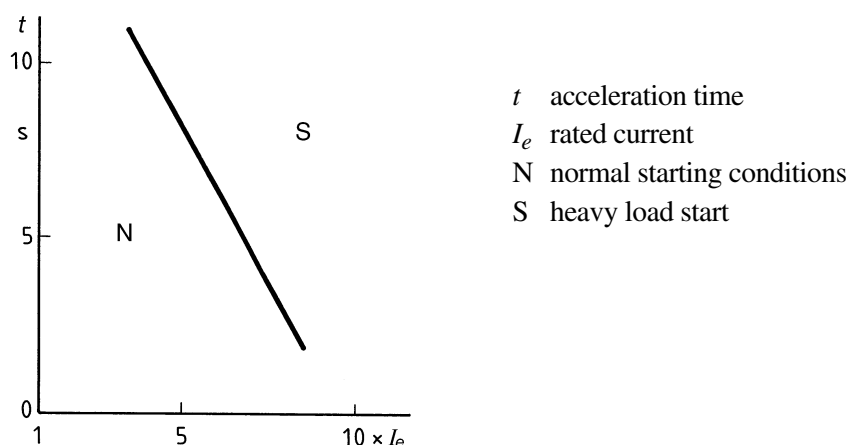

Fig. 6.9.1 During heavy load start, the acceleration time is a function of the starting current and amounts to a few seconds.

For these cases, electronic motor overloads can be adapted exactly to the motor's heavy load start (**Chapter 6.6**). Therefore, temporary circuits with thermal relays like saturation transducers, protective relay bridging during start and separate thermal relays for the start phase, are no longer required.

6.5 Motor protection in rooms with a risk of explosion

Thermal relays for the protection of EEx e - motors have to comply with the standards and regulations outlined in **Chapter 3.4**. The thermal relays themselves are not explosion-protected and therefore must not be installed in the danger zone.

In countries with a general test requirement, motor protectors for the protection of EEx e - motors can be used if the motor's t_E - time corresponds to the minimum values or is longer. If this is not the case, the motor's t_E - time must be compared with the characteristic tripping curves values in cold condition. Protection is guaranteed if the values at least correspond to the curve or even exceed it.

In addition, it has to be checked for motors in delta connection whether the tripping time for two-pole tripping corresponds to the 0.87-fold of $I_A/I_e \leq t_E$

Electronic motor overloads (**Chapter 6.6**) permit the t_E -time to be set exactly. This means that during a heavy load start, the permissible t_E - time can be fully utilised.

6.6 Electronic motor protection

Electronic motor overloads provide the possibility of projecting the thermal conditions within the motor for each operational type far more accurately than would be the case, for example, with thermal relays on bimetallic basis. At the same time, the newly acquired information helps to extend the protector's application range.

The main properties of electronic motor overloads are:

- accurate current setting
- improved protection for different start and operating conditions
- extended protective, checking, monitoring and control functions.

6.6.1 Overload protection

6.6.1.1 Thermal projection models

With regard to accuracy, it is not important, in principle, whether the devices are implemented on an analogue or digital basis. These devices, which are equipped with microprocessors, are also partially suitable for communication with higher-order control systems and can, for example, be connected to bus systems. Depending on requirements, the devices are used in practice in accordance with the following models:

- *Single-body model*: simple electronic motor overloads simulate motor warming only on the basis of a thermal single-body model. Their characteristic heating and cooling curves could be compared with thermal relay conditions. They only consider the stator winding's heating capacity and, therefore, cool down too quickly during motor standstill, since the iron is not taken into consideration. Therefore, the motor has to be protected by additional thermal sensors during load changes and intermittent operation.
- *Two-body model*: complex electronic motor overloads simulate the motor heating on the basis of a thermal two-body model. The simulation is based on a consideration of the stator winding's heating and the motor's iron mass. This helps, for example, to accurately project the fast heating of the winding during a heavy load start as well as the following heat transfer from motor winding to the iron, which heats up considerably more slowly. During running, the iron losses, as well as losses caused by asymmetry, are also fed into the simulation model. A consideration of the motor's ambient temperature increases the maximum utilisation of the system, even during large temperature fluctuations. The different cooling conditions of a self-ventilated motor during run and standstill are taken into consideration by means of two different time constants. After switch-off, the winding's rapid cooling-down to iron temperature and the subsequent slow cooling of the motor as a whole is projected.

This means that the thermal projection of the electronic motor protector corresponds to the motor's condition at all times. This enables maximum system utilisation and guarantees safe motor protection, even during difficult starting and operating conditions.

The two-body simulation can be explained using a capacity-resistance network as shown in **Fig. 6.12.1**

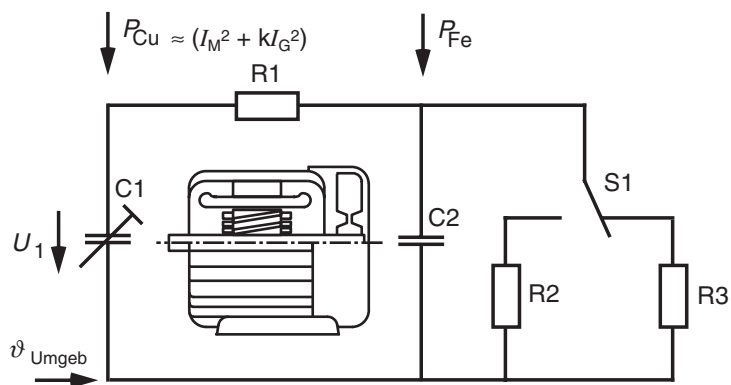

Fig. 6.12.1 2-body projection to simulate motor warming.

- C1 capacity in accordance with the winding's heat capacity (adjustable)
- C2 capacity in accordance with the heat capacity of the iron and other machine mass
- R1 resistance in accordance with the heat transfer resistance between winding and iron
- R2 resistance in accordance with heat losses to the environment during standstill
- R3 resistance in accordance with heat losses to the environment during run
- P_{Cu} feeding of a current in proportion to copper losses
- P_{Fe} feeding of a current in proportion to iron losses
- S1 change-over standstill/run
- I_M motor current
- I_G counter-component caused by asymmetry
- v_{Umgeb} consideration of ambient-/cooling medium temperature with Pt 100-sensor.

6.6.1.2 Current setting

Observing the permissible temperature for continuous motor operation ensures that the insulation's life span is secured. For this reason, the correct current setting is very important. If the current were set too high, the protection of the machine could not be granted anymore. The setting has to reflect possible factors which deviate from normal conditions, like too high a coolant temperature, as shown in **Table 6.8.1**, or the installation of the motor above 1000 meters above sea level. See **Table 6.9.1**.

With modern electronic motor overloads, the rated current is set directly and digitally in Amperes.

If primary current transformers have been pre-switched, their ratio must also be considered.

The system in operation is also protected if the required lower operating current is set at the motor protector instead of the rated current. A higher load, e.g. through mechanical faults, is detected and the system can be switched off, as long as the damage is small.

6.6.1.3 Setting the tripping time

By setting the tripping time, the electronic motor overload tripping characteristics are adapted to the motor's thermal capacity. The optimal setting of the tripping time is possible if the motor's permissible locked rotor from cold and its corresponding stalling current are known. See Fig. 6.13.1 Both values can be defined by the motor manufacturer.

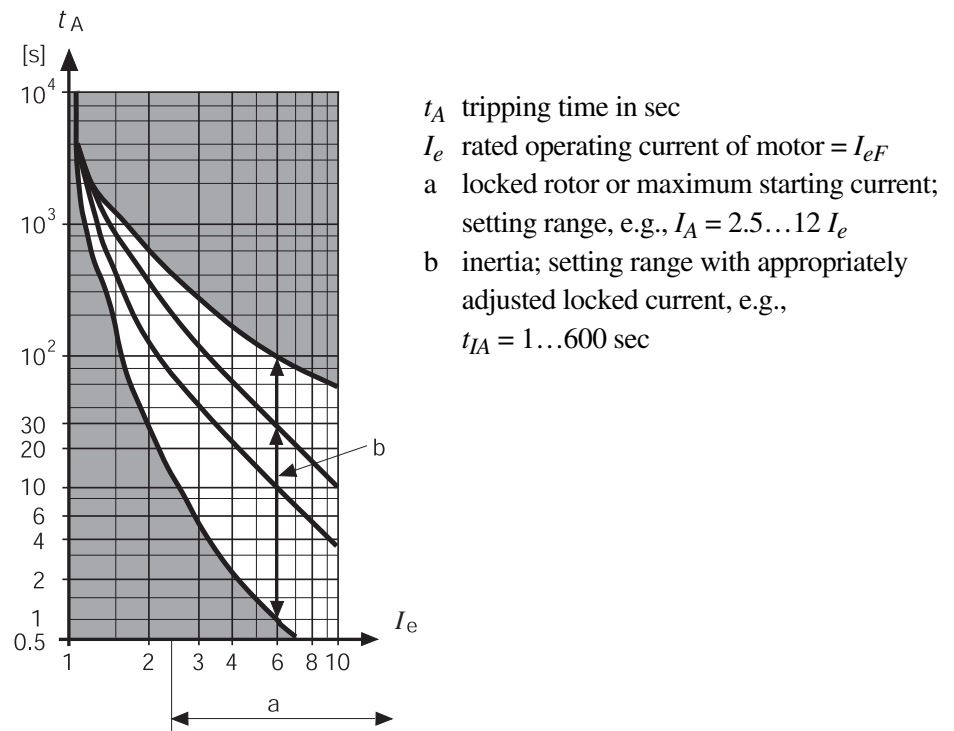

Fig. 6.13.1 Time-/Current curve of an electronic motor overload (from cold condition).

In many cases, the permissible stalling time is unknown. But if the motor has been correctly dimensioned for the particular application, the following tripping times are recommended:

- *Standard motors:* the normal setting is 10 s
- *Special motors, like thermally fast drives:* one begins with a start trial with setting 2 s. If the motor overload trips, the motor is allowed to cool down. Then it starts again with the set 4 s and increases the trip time until the start is successful.

6.6.2 Special motor protection functions

6.6.2.1 Phase failure

Electronic motor overloads can recognise a phase failure independent of the load and can react immediately.

Different solutions are used:

- *Differential trip*: the tripping curve is shifted, similarly to the thermal relay, by means of an electronic differential trip. If the motor is not fully loaded, it can continue to run.
- *Fast cut out*: this prevents unnecessary further heating up of the motor and protects motor and system bearings. The trip is often delayed by a short period of time in order to prevent an unnecessary cut out in the supply net during short, single-phase interruptions.

6.6.2.2 Asymmetry

Asymmetrical phase voltages are mainly caused by long power lines. The resulting current asymmetry in the motor windings amounts, depending on the motor design, to 6...10-fold of the voltage asymmetry.

Medium-sized and large low-voltage motors are quickly at risk thermally (rotor-critical motors). For this reason, the load must be reduced as shown in **Fig. 2.9.1** in order to prevent the motor from overheating. Some electronic motor protection devices detect the asymmetry and correct the trip limit downwards. In practice, however, it is not always possible to reduce the motor load. The overload, however, can emit a warning signal.

For asymmetrical feed, it is normally not only one motor but the entire system that is affected. It is therefore advisable to centrally control the mains voltage. In systems with a “bad” network with regularly asymmetrical mains voltage, the motors must be sized accordingly in order to prevent a negative effect on their life span.

Higher asymmetries or the failure of a phase can be caused by defective contacts on power circuit breakers, contactors, terminals, failed fuses as well as by motor-internal faults. Fast detection and cut out prevent overheating damage on these devices. The system and motor bearings are protected.

Definition of voltage asymmetry in accordance with NEMA and IEC:

$$\Delta U (\%) = \frac{\text{Maximum deviation from the phase voltage average} \times 100}{\text{phase voltage average}}$$

6.6.2.3 Short-to-earth

Insulation damage on motors is often caused by high voltage surges. Sources are lightning bolts, network changes, capacitor discharges and power electronics devices. Further causes are ageing, continuous or cyclical overloads, as well as mechanical vibrations and foreign bodies. Most insulation damage leads to shorts against earthed machine parts. In earthed networks, the earth currents can quickly reach high values. Depending on the network type and the requirement, the earth current has to be monitored using either the “Holmgreen” method or by means of a cumulative current transformer.

Short-to-earth using the “Holmgreen” method (rigidly earthed networks)

In order to detect a leakage current in rigid or low ohmic earthed networks, current in the three phase conductors are normally measured. For a healthy motor, the total of these currents equals zero. But if a current flows to the motor housing and thus into the earth, a residual current I_0 occurs at the transducer star point, which is proportional to this earth current. It is detected by the leakage detector and causes a trip. A short delay prevents erroneous trips by transient transducer saturation which can occur during switching operations. A sensitivity must be chosen so that neither transducer transmission errors, nor interfering signals in start-delta connection caused by the third upper harmonics, can lead to false trips. Fig. 6.15.1

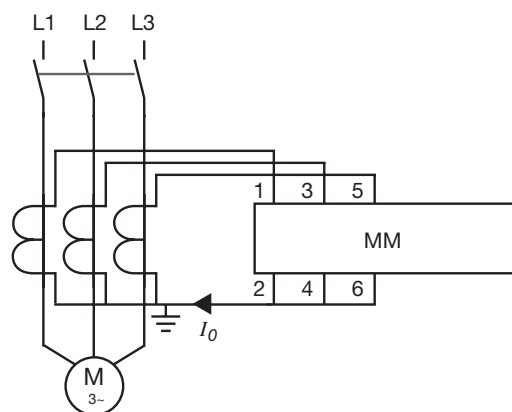

Fig. 6.15.1 Short-to-earth protection using the “Holmgreen” method

T1 main current transformer

MM motor protector

I_0 residual current (proportional to leakage current)

Short-to-earth using cumulative current transformers

In insulated, high-impedance earthed or compensated networks, the high sensitivity required is achieved by means of a cumulative current transformer whose core covers all three conductors leading to the motor. In accordance with the leakage current-protector switch principle, sensitive protection against leakage is possible. If the response threshold is low, a small insulation defect is already sufficient to trigger an early warning or disconnection. **Fig. 6.16.1.**

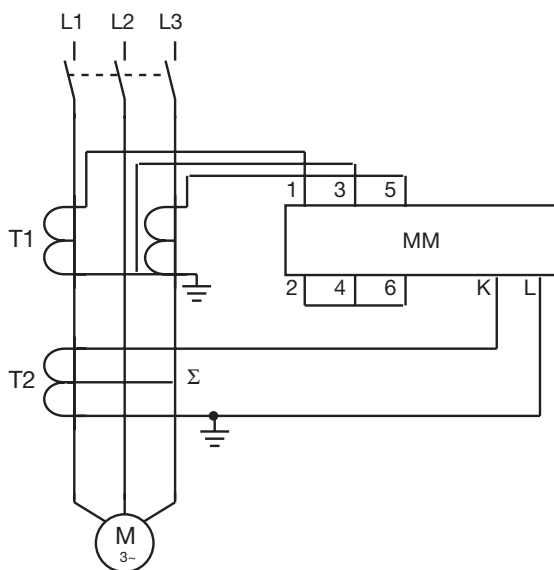

Fig. 6.16.1 Leakage protection using cumulative current transformer

- T1 main current transformer (2-phase current detection)
- T2 cumulative current transformer
- MM motor overload

Applications

- medium-voltage motors
- systems in difficult surroundings, for example, dampness, dust, etc., in mines, gravel quarries, cement factories, mills, wood processing, water pump works, water treatment plants, drainage

Leakage protection in medium voltage networks

The following passage aims to give an overview of the conditions for earth faults in insulated, high-impedance earthed or compensated networks. This overview is by no means exhaustive and does not consider transient effects.

For networks with the above-mentioned star-point earth types, the size of the earth fault current is determined by the networks earthing capacity and the earthing resistance or the compensating inductor. It is typical for relatively small industrial networks that the earth currents are very small. The earth capacity is mainly determined by cables and motors.

The capacity values of cables can be found in cable tables, and are within the range of 0.2...1.2 μF per kilometre length. For medium voltage motors, a value of approx. 0.02...0.05 μF per megawatt motor output can be expected.

It is a further general rule for industrial medium voltage networks that per 1000...1500 KVA system output approx. 1 Amp capacitive earth current can be expected. For the entire network to be monitored, a star point monitoring is carried out by measuring the translocation voltage.

Leakage detectors in the motor branches help to locate the earth fault. In many cases, operation can be continued, as the earth currents which occur are relatively small and the insulation of the healthy phases can be operated with a higher voltage for a short period of time.

Isolated or high-impedance earthed networks

For symmetrical earth capacities, the star point of the undisturbed network assumes the earth potential and the total of the currents flowing via the earth capacitance is zero. Also the high-impedance earth resistance (**Fig. 6.19.2/6.20.1/6.20.3**) is cold for transformers with star points during normal operation. It prevents extreme overvoltages during intermittent earthing faults, which can occur in isolated networks. The rating is normally such that the resistor, during an earth fault, carries a current which is approximately as high as the networks capacitive charging current.

If, for example, the pole conductor **Fig. 6.19.1** and **Fig. 6.19.3** is linked with the earth following an earth fault, the other two pole conductors lead a voltage between lines against earth. Through their earthing capacities C_N (on network side, as seen from protector MM) and C_M (on motor's side), a capacitive current flows against earth and via the faulty area back to pole conductor 3. For a high-impedance earthing, **Fig. 6.19.2/6.20.1/6.20.3**, the voltage of the high star point drives an additional current across the faulty area, which is limited by the earth resistance.

In case of an earth fault on the measuring point's network side (installation point of current transformers), the current protector MM measures the part of the earthing current flowing across C_M . A response sensitivity must be selected which prevents the MM from tripping in this case. On the other hand, the MM should as accurately as possible, detect earth faults which occur, since for earth faults in the motor's windings, the transitional voltage decreases the closer the fault point is to the star point. The leakage current decreases proportionally. Normally, the response threshold is not selected below 5...10 % of the current for a saturated earth fault on the motor terminals.

Compensated networks

Deleted networks, resonance earthing, compensation coil.

Figures 6.19.2/6.20.1/6.20.3 also show the principal conditions for compensated industrial networks, although those are relatively rare. During full compensation, the compensation coil provides a current as high as the capacitive leakage current, but with reversed phase position, so that only the very low ohmic leakage current passes via the faulty area.

Schematic representation of different network types and earthing positions

The earth current measured by an electronic motor protector MM by means of a cumulative current transformer depends on the network type and the earthing position. The following diagrams show the conditions for different applications.

Legend for following diagram:

K1	contactor
MM	motor protector
M1	motor
C_N	earth capacity of pole conductors - network side
C_M	earth capacity of motor, including cables between current transformer and motor
L	compensation coil
R	high-impedance earthing resistance
T	transformer
I_E	earth leakage current

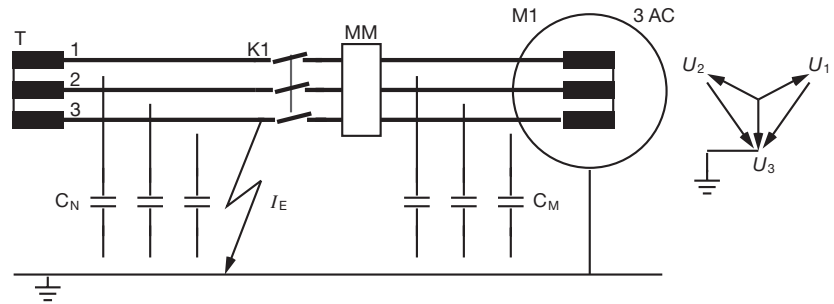

Fig. 6.19.1 Insulated network:
Earth fault on network side. The MM measures the earth current content through C_M

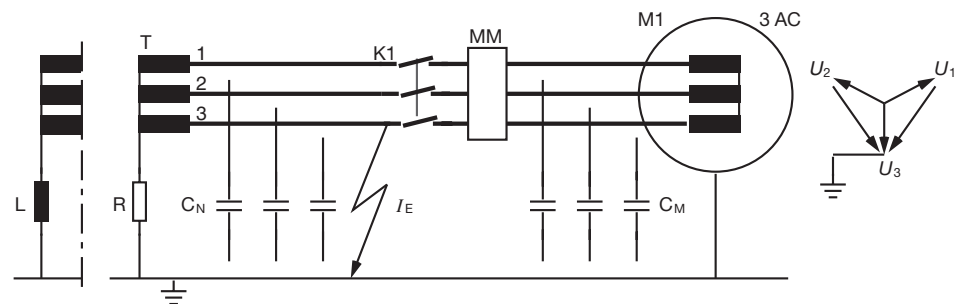

Fig. 6.19.2 High-impedance earthed network:
Earth fault on network side. The MM measures the earth current content through C_M
Compensated network:
A small current flows across the faulty area. It is determined by the vector sum of the earth currents

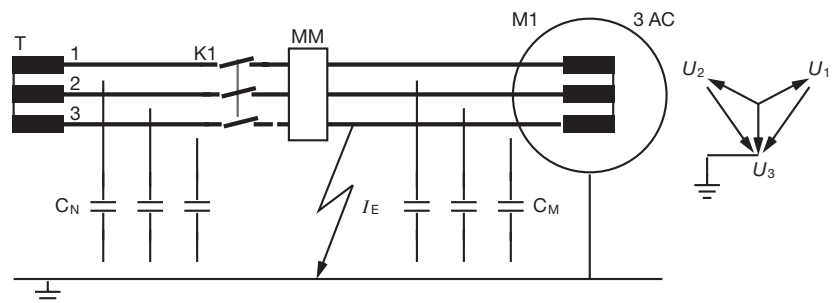

Fig. 6.19.3 Insulated network:
Earth fault on motor's side on supply lines: the MM measures the earth current content via C_N .

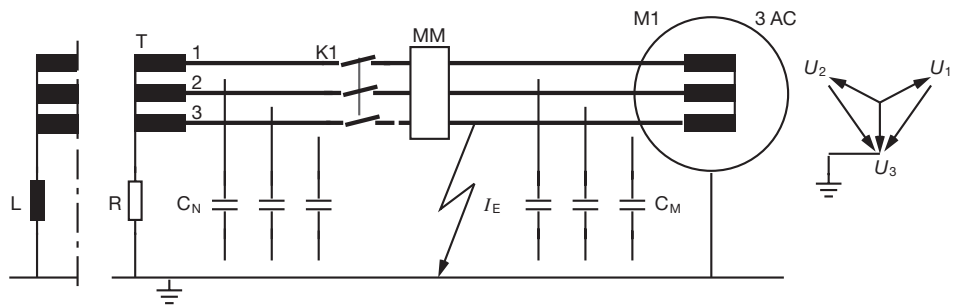

Fig. 6.20.1 High-impedance earthed network:
 Earth fault on motor's side on supply lines. The MM measures the vector sum of the earth currents via C_N and the earthing resistance R . The MM measure the vector sum of the earth currents via C_N and the compensation coil L .

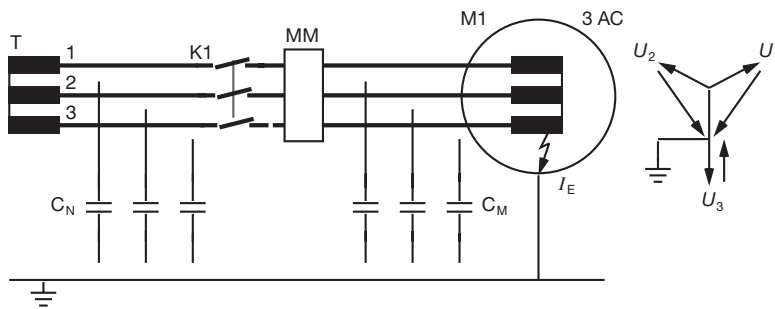

Fig. 6.20.2 Isolated network:
 Earth fault in motor. The closer the fault point is to the motor star point, the smaller the leakage current

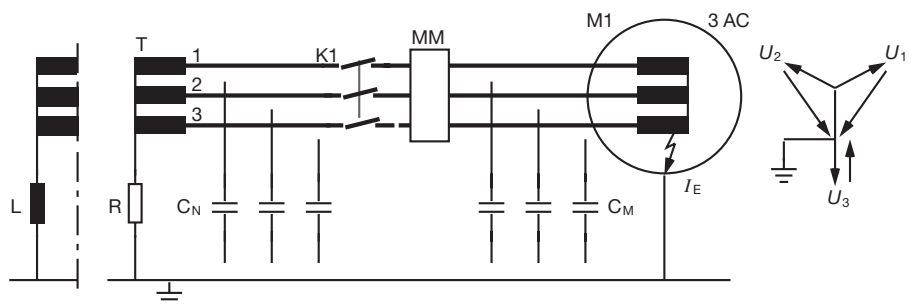

Fig. 6.20.3 High-impedance earthed network:
 Earthing fault in motor. The MM measures the vector sum of the C_N -earth currents and the earthing resistance R .
 Compensated network:
 The MM measures the vector sum of the earth currents via C_N and the compensation coil L . The closer the fault point is to the motor star point, the smaller the leakage current.

6.6.2.4 Short-circuit protection of medium-voltage motors

High phase voltages, caused by phase shorts and shorts from phase to earth, are detected. Via the pre-switched power circuit breaker, the supply can be interrupted. The short circuit protection is normally always in operation. For this reason, the response level has to be set a little above the maximum starting current.

Tripping must be delayed by approximately 50 ms. On the one hand, this permits the quick operation of the power circuit breaker and, on the other hand, prevents undesired cut off as a result of current peak.

During a short circuit, a separate output relay trips independently of the remaining protection functions. This activates a power-circuit breaker with sufficient breaking capability. In order to prevent the contactor being switched off under short circuit conditions and therefore destroyed, the output relay for thermal protection has to be blocked for currents exceeding $>12 I_c$. See Fig. 6.21.1 and 6.22.1

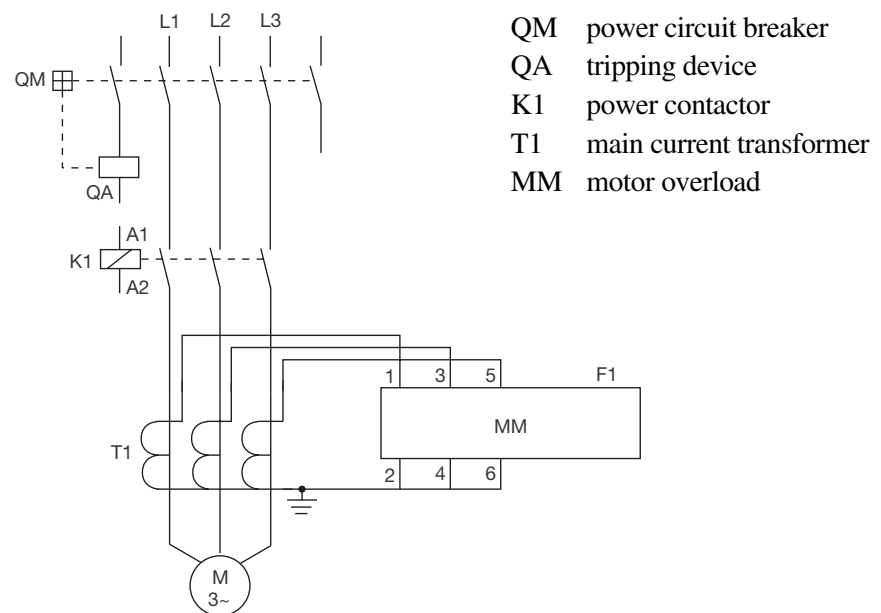

Fig. 6.21.1 MM for short-circuit protection.

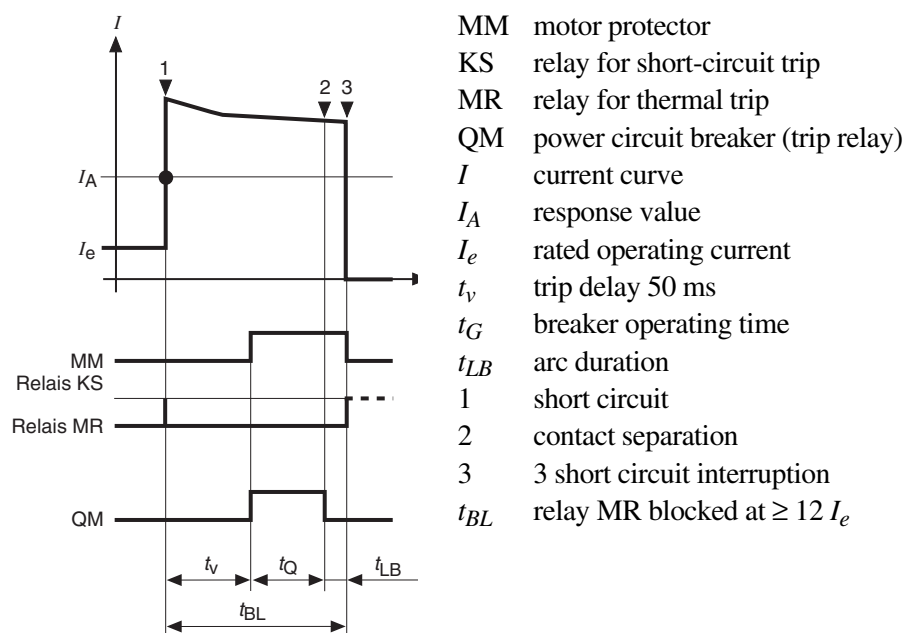

Fig. 6.22.1 MM Short circuit power cut diagram.

6.6.3 System-protection functions

6.6.3.1 High overload and stalling

During impermissibly high overloads and stalling, an immediate system shut-down avoids unnecessary mechanical and thermal strains on motor and power transmission elements. This reduces accidents and production losses. A slowly developing overload can be detected and reported very early on (e.g. bearing damage). The protective function is enabled after successful motor run-up, upon reaching the operating current. Fig. 6.23.1.

Applications

- transport systems
- mills
- mixers
- crushers
- saws, etc.

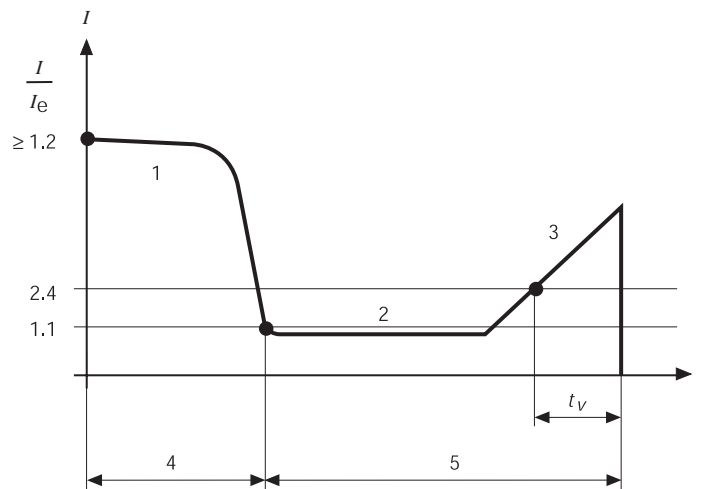

Fig. 6.23.1 Protection function - high overload and stalling.

- | | | | |
|---|------------------------------|-------|---|
| 1 | motor start $I \geq 1.2 I_e$ | t_v | trip delay |
| 2 | rated operation | 4 | stalling protection inactive |
| 3 | high overload or stalling | 5 | stalling protection active (trip threshold) |

6.6.3.2 Underload

Motors which are cooled by the pumped medium itself (e.g. underwater pumps, ventilators) can become overheated, despite being underloaded, if there is no pumping medium or its quantity is insufficient (blocked filters, closed gates). In many cases, these machines are used in locations which are not easily accessible. The consequences are lengthy repair periods and correspondingly high costs. If a specific current is not achieved, this can also indicate a mechanical fault in the system (torn transport belts, faulty ventilator blades, defective couplings, broken shafts or worn tools). These conditions do not put the motor at risk but lead to production losses. Fast detection helps keep damages to a minimum. It must be possible to delay the underload protection's release following a start, in order to prevent tripping for as long as, for example, the gate or valve has to remain closed. Fig. 6.24.1

Applications

- underwater pumps
- ventilators
- transport systems
- detection of fractures in mechanical transmission systems

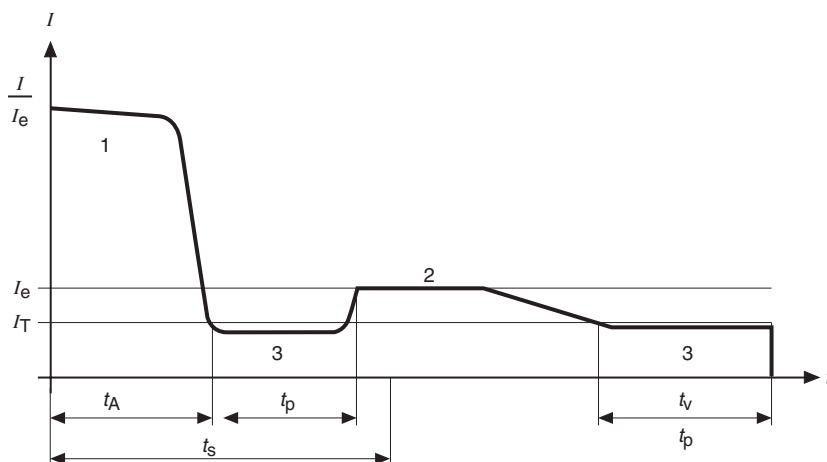

Fig. 6.24.1 Function of underload protection.

- | | | | |
|-------|---------------------|-------|-----------------------|
| 1 | start | t_s | delayed release |
| 2 | rated operation | | underload protection- |
| 3 | underload operation | | release inactive |
| t_A | start time | t_v | trip delay |
| I_T | trip threshold | t_p | warning |

6.6.3.3 Incorrect rotation protection

The rotation protection detects the phase sequence in the induction network and trips if it is incorrect.

Two different methods are possible:

- *constant monitoring*: the applied network voltage is monitored constantly. If an incorrect phase sequence is detected (sense of rotation in the induction network), motor starting is prevented.
- *reaction only after start*: the protection device reacts only after the motor has been started and a measurable current is flowing. A low inertia, quick-response system can, however, start up with the incorrect rotation and suffer damage.

6.6.3.4 Start time monitoring

The start time is monitored. If start has not been achieved during the preset period of time, the system can be switched off. This monitoring procedure is independent of the motor's thermal condition.

Applications

- Systems which require an increased load or stalling of the drive to already be detected during starting in order to avoid greater damage. Possible causes: overloaded systems, defective bearings or transmission elements. **Fig. 6.25.1**

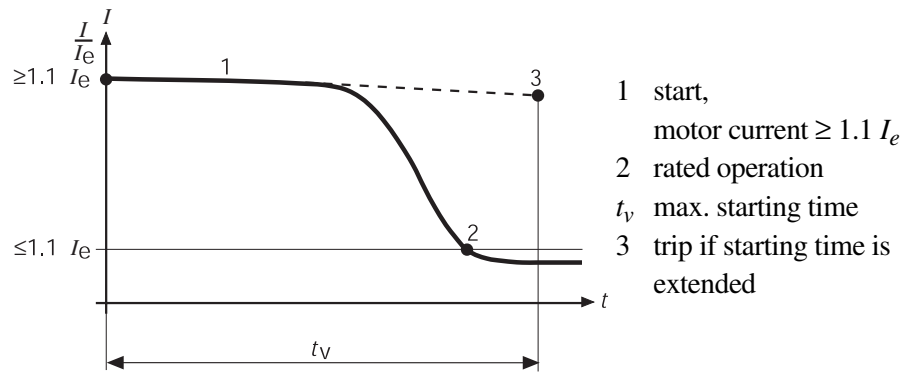

Fig. 6.25.1 Starting time monitoring.

6.6.3.5 Stalling during start

If a drive is stalled during the start phase, the motor heats up very quickly and reaches the insulation's limiting temperature, after the permissible stalling time has expired. Large low-voltage motors and, above all, medium voltage motors, mostly have very short permissible stalling times but permit considerably longer starts. In order to guarantee start, the stalling time very often has to be increased. With the help of an external rotation pick-up or standstill pick-up, the overload detects a stalling during starting and cuts out the motor immediately. This means that the motor and the power system are not subjected to unnecessary strain during a stall.

During operation, an overload or a stall is detected using the function "high overload and stall". See Fig. 6.25.2.

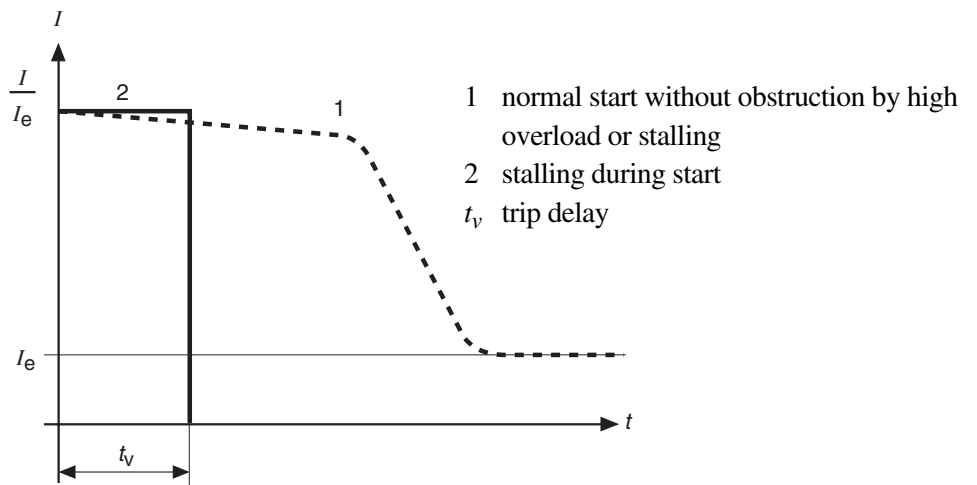

Fig. 6.25.2 Stalling during start.

Applications

- large low-voltage motors
- medium-voltage motors
- transport systems
- mills
- mixers
- crushers
- saws
- cranes
- elevating platforms

6.6.4 Control functions

Besides their protection functions, electronic motor overloads also have control and communication tasks. In a hierarchically constructed control system, these devices can be combined with manual control or be embedded in the network. In particularly sensitive motor protectors, which implement temperature simulation, for example, on the basis of a two-body model, besides the motor's current take-in, its heat load can also help utilise and control a process for optimal performance.

6.6.4.1 Pre-warning

It is often not desired to shut a system down immediately, if an unusual (standard-deviating) situation occurs. A pre-warning can prove useful to reduce a load or, for example, to permit an earth fault to be corrected only during the next operational pause.

A distinction is made between:

- *current-dependent pre-warning for:*
 - overload under the stalling threshold
 - underload
 - asymmetry
 - earth faults.
- *temperature-dependent pre-warning for:*
 - below the limiting temperature

6.6.4.2 Load control

For mills, stone crushers, or delivery systems, the motor load can be controlled or optimised. If the motor protector copies the motor temperature accurately, it is possible to adjust the system to the maximum rated temperature, even with load changes. This allows optimal system use. The control procedure can be carried out manually, based on the heating display, or via a central control mechanism.

6.6.4.3 Start lock-out

Motors which have been switched off following overheating can only be re-started after the motor has cooled down sufficiently and the protector's release has been re-set. It must, however, be taken into consideration that only an accurate copying of the cooling down process ensures that the motor is not put at risk during re-start.

In order to ensure the re-start of a stationary warm motor following an operational shut-down, the motor has to cool down until it has sufficient thermal reserves. The connection shown in Fig. 6.27.1 prevents premature, unsuccessful starting attempts and additional strain on the motor.

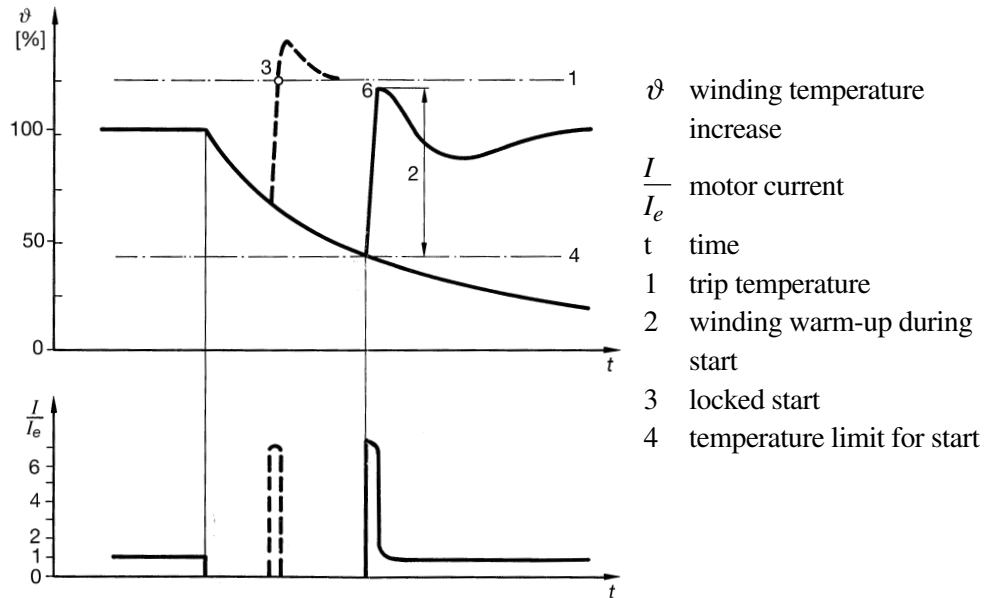

Fig. 6.27.1

6.6.4.4 Star-delta change-over

Since the motor current is measured continuously, it is possible to control the start-delta connection independently of the load and optimise with regard to time.

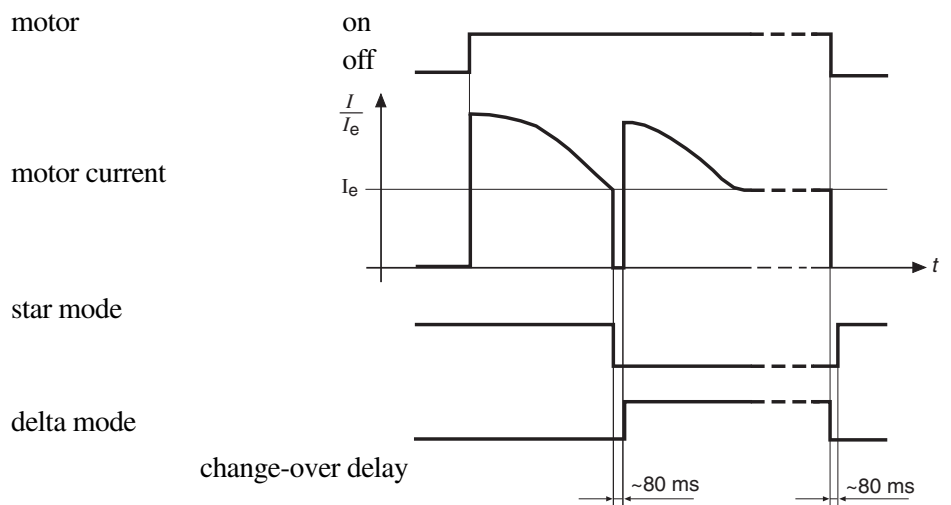

Fig. 6.27.2 Star-delta starting diagram

6.6.4.5 Warm start

For a short time, the motor windings can be heated above the permitted temperature limit. This applies to rotorcritical motors in particular. The rotor temperature, which is permitted for a short period of time, amounts to 250 °C, which is considerably higher than its temperature 100...150 °C for continuous operation. This results in a relatively long permissible starting time of the motor, which is still warm from the previous operation. In general, this time is only a little shorter than during cold motor starting. This property of a motor can be utilised by a particularly sensitive motor overload without adversely influencing the correct temperature reproduction. **Fig. 6.28.1.**

An additional “limiting of the number of starts” can prevent too many warm starts.

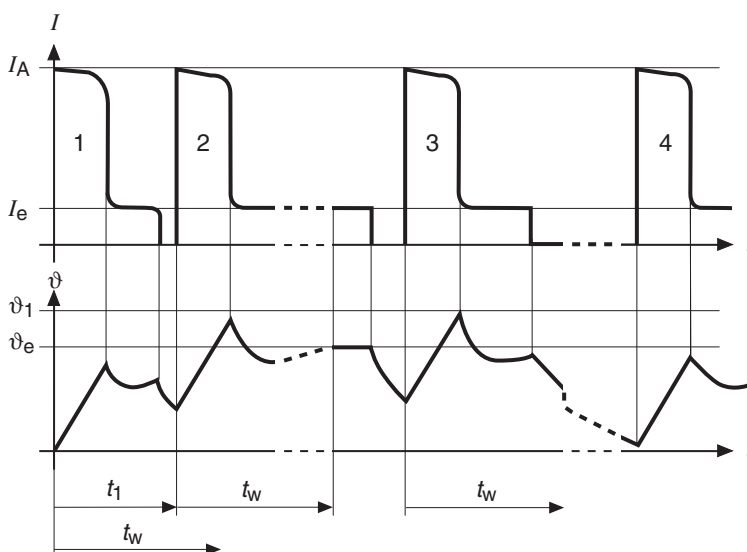

Fig. 6.28.1 Current and temperature curve during motor cold and warm start and tripping thresholds (e.g. SMM 825)

- | | |
|--|---|
| I_A starting current | 1 1. start (cold start) |
| I_e rated current | 2 1. warm start |
| ϑ_e permissible motor temperature for continuous motor operation and normal tripping threshold | 3 2. warm start |
| ϑ_1 motor temperature, permissible for a short period of time, and tripping threshold for a motor overload with modified tripping curve for warm start | 4 cold start (after the motor has cooled down) |
| | t_1 min. time before 1. warm start is possible ($t_1 > 10 t_{6 I_e}$) |
| | t_w minimum time between 2 warm starts (4 .. 60 min) |

Applications

All systems which have to re-started immediately and safely following a voltage disconnection.

- Chemical processes and production systems, e.g.:
 - mixers
 - centrifuges
 - pumps
 - transport systems
- Mines and tunnels , e.g.:
 - fresh air ventilators
 - passenger lifts
 - water pumps
- Water supplies
- Drainage

6.6.4.6 Possibilities for communication

Modern electronic motor protectors permit processing, saving and access to all relevant and statistical data, using microprocessor technology:

- output (motor) current
- asymmetry
- earth current
- temperature increase
- thermal capacity
- time until trip
- period of operation
- data about condition of contactor and motor
- cause and time of previous warnings and trips

All this data can be communicated via the central control and the operator's console control or network connection. It is also possible to continuously adapt the operation parameters stored in the motor overload via the network to changing process requirements.

Motor overloads of a modular design provide a connection for the most important bus protocols.

6.6.5 Applications of electronic motor overloadse

6.6.5.1 Low thermal inertia motors

Among these motors are, for example, underwater pump motors, hermetically sealed cold compressors etc, which are in most cases equipped with a highly efficient cooling systems. Their permissible stalling time is usually short, since the windings have been designed for a high specific loads.

These drives require the tripping time to be adjusted to 2...4s. The underload protection is particularly useful for underwater pump motors, since they are not cooled if the pumped medium is absent and, therefore and are quickly put at risk thermally.

6.6.5.2 High thermal inertia motors

If a large inertia mass with long starting times is to be driven, as is the case, for example, with ventilators, centrifuges, mixing systems etc., motors with oversized windings and cages are often used.

For these drives, electronic motor protection is particularly suitable, since they are able to copy the temperature increase correctly during starting. In order to achieve a correct setting, the permissible stalling time and its corresponding stalling current must be known.

6.6.5.3 Rotorcritical motors

Medium voltage and large low voltage motors are, in most cases, rotorcritical. The permissible stalling and starting time is limited by the rotor's thermal capacity and is specified by the motor manufacturer. If the motor protector's tripping time is set to the permissible stalling time, then the thermal projection reflects the motor's practical requirements.

For a short period of time, high temperatures are permitted within the rotor. For this reason, the motor is overprotected during a start from warm.

If rotorcritical motors are used under heavy load start conditions, it has to be borne in mind that they reach their critical temperature very quickly during stalling. For this reason, the starting time for a heavy load start has to be set to a considerably higher value than the permissible stalling time. In order to guarantee stalling protection during start even under these conditions, the speed has to be monitored during the start phase by means of a rev or standstill counter. During operation, the protector also has to react immediately to a stall condition.

6.6.5.4 Medium voltage motors

Medium voltage motors are used from an output of approximately 200 kW onwards. Their structure and function is the same as for low voltage motors. They are, in general, rotorcritical and therefore must be protected accordingly.

6.6.5.5 Slip-ring motors

Even after repeated re-starts, slip-ring motors are not put at risk thermally. The starting heat losses are transmitted to the starting resistors outside the motor. In general, it is easier to protect self-ventilated slip-ring motors than ordinary squirrel-cage motors, since they do not have a current displacement and they are not operated with increased slip for longer periods of time.

Not only the slip-ring motor's stator, but also its rotor contain temperature-sensitive insulating materials. For this reason, the tripping time is determined by the thermally critical part. The permissible stalling and starting time is specified by the motor manufacturer. If the degree of inertia is set properly, modern motor protectors also protect the starting resistors against a thermal overload. Due to the deep frequency (slip frequency), it is not easy to establish the correct current values in the rotor circuit.

The rotor current is approximately proportional to the stator current measured by the motor protector. Therefore, protection can be achieved even when energy is re-fed from rotor to network, for the sub-synchronous static conversion cascade for low speeds. It is a precondition that cooling, e.g. by remote ventilation, is guaranteed.

6.6.5.6 Multi-stage motors

Multi-stage motors are implemented by sectional windings or by switch-over winding sections, like the Dahlander connection. These winding sections are banked in the same slots and are therefore very tightly thermally coupled or even identical. For this reason, the winding of one stage also heats up the other one during continuous operation. After a longer operation period, both will reach the same temperature.

It is common practice to use a separate motor protector for each speed. This method, however, has the disadvantage that the second protection device does not measure the thermal operation condition of the previous stage during change-over from one speed stage to the other. It requires a certain time to heat up sufficiently to provide the motor with protection against overload.

An accurate temperature projection and thus safe protection is possible if the overload offers two different current settings and measures the motor currents of both stages.

6.6.5.7 Frequency controlled motors

It has to be borne in mind that the cooling of self-ventilated motors is not fully guaranteed at low speed. The motor temperature rise is not only dependent on the motor current. **Fig. 6.32.1.** Additional losses of approximately 10 % occur due to harmonics.

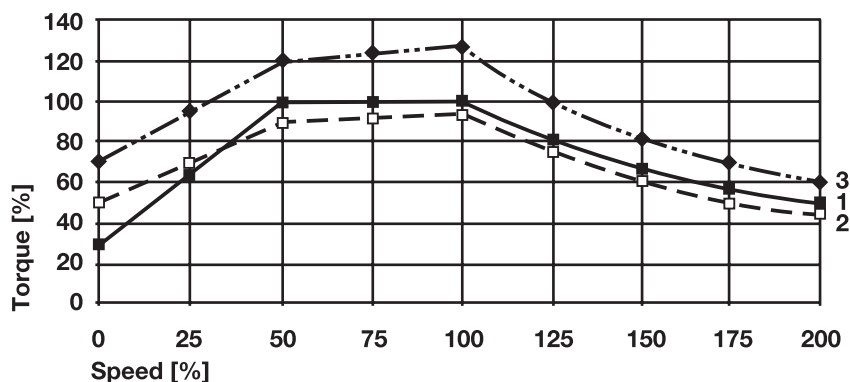

Fig. 6.32.1 Permissible continuous thermal load for an induction motor controlled by a variable speed drive.

- 1 load torque
- 2 torque of a standard motor with permissible continuous load
- 3 torque of a standard motor of next higher standard output

For this reason, these motors should also be equipped with temperature sensors, e.g. PTC-sensors.

Current-dependent protection can already be included in the static converter or can, independently of the frequency, be achieved by means of external devices:

- thermal relay on bimetallic principles
- power circuit breaker
- electronic motor protectors with integrated PTC-protection

The permissible frequency range, as well as the influence of the high switching frequencies in the frequency converter, have to be considered when choosing a particular type of protector.

6.6.5.8 Soft start, soft stop

Not all motor overloads are suitable for protecting motors which are activated by means of soft start devices based on phase control. During the starting, currents occur which considerably deviate from the sine shape and which can obstruct certain protection functions. For this reason, the affected functions must be switched off during the start and soft stop phase in basic overload devices.

If the soft starter is also equipped with a braking function, the overload has to ignore the asymmetry occurring during the brake phase.

If motors are operated with reduced voltage for a prolonged period of time, they have to be additionally protected by means of temperature sensors (e.g. PTC).

6.6.5.9 Motors with remote ventilation

The cooling of remotely ventilated motors does not depend on the motor speed. These drives are usually cooled further for a certain period of time after they have been switched off. The fast cooling down of the motor can be considered in an electronic overload.

6.6.5.10 Increased ambient temperature

If the coolant temperature exceeds 40 °C, the machine must only be operated with reduced power. This problem can also occur during normal ambient temperatures if the temperature increases drastically, e.g. through sunlight or other heat sources.

In principle, this problem has already to be borne in mind during planning. The drive must be sized accordingly, or a higher insulation class must be chosen and the motor overload must be adapted to these conditions. Certain applications deliberately take into account a corresponding reduction in the life span. The following solutions are common for an increased ambient temperature:

- Correct trip characteristics of motor overload and system load in line with ambient temperature. Particularly sensitive protectors automatically take into account the ambient temperature in the temperature simulation model by means of temperature sensors, e.g. PT100.
- Correct current setting : a thermostat switches the current setting in the motor overload to pre-selected values in line with the ambient temperature. This is possible for overloads designed for the protection of two-stage motors with two current settings which can be activated. The thermostat can also control the drive's load at the same time.

6.6.5.11 Motors in explosion-risk areas

The operation of electrical devices for zones 1 and 2 requires permission. Zone 2 is the less demanding environment, since the possible disturbance may only occur for a short period of time. An atmosphere at risk from explosion may only be present for a short period of time and not during operation.

In accordance with the corresponding ignition class, the motor requires the time t_E in order to heat up from its operational warm condition to the critical temperature. The motor overload trip time must, for this reason, correspond to time t_E or be shorter.

Contrary to bimetallic thermal relays, electronic motor protection relays also take into account the cooling down time, resulting in an increased protection reserve compared to the bimetallic thermal relay.

6.6.5.12 Protection of compensated induction motors

During single compensation, the capacitors required for reactive power compensation are directly connected to the motor terminals. (Exception: if soft starters are applied in line with 6.6.5.8, the capacitors must be installed in front of the soft starter). This means that motor and capacitor are simultaneously switched on and off. The supply lines from the network and the switching and protection devices carry only the compensated current, since the reactive current flows mainly between capacitor and motor.

The compensated current is the geometrical sum of the motor's reactive current, reduced by the capacitor's reactive current, and the motor's active current. Instead of the motor's rated operating current, the correspondingly compensated current has to be set at the overload. The latter can only be measured if the motor is fully loaded and is therefore mostly calculated using the following general formula:

$$I_{eF} \approx I_e \frac{\cos\varphi_N}{\cos\varphi_2}$$

I_{eF} set current in Ampere
 I_e rated operating current of motor in Ampere
 $\cos\varphi_N$ power factor of motor for I_e
 $\cos\varphi_2$ compensated power factor

While I_e and $\cos\varphi_N$ can be found in the manufacturer's specifications or on the rating plate, it is rather difficult to measure or calculate $\cos\varphi_2$. If $\cos\varphi_2 = 0.95$ is assumed for correctly rated capacitors, motor protection is guaranteed.

For group and central compensation, the overload carries the same (uncompensated) current as the motor and must therefore be set to its rated operating current.

7 Selecting the correct motor overload

An economic motor protection concept requires the overload to be adapted to the requirements of the motor and the system to be operated.

It is not feasible to protect an uncritical system with high-quality devices. On the other hand, however, the damage can be considerable if an important part of the production plant with difficult starting and operating conditions is not appropriately monitored and protected.

The following tables should simplify the correct choice of overload or combination of different devices. For every application, all relevant criteria must be considered and taken into account again.

The main selection criteria are:

- application
- drive type and motor size
- ambient conditions
- motor management requirements

7.1 Application-dependent overload selection

Application	Shears	Presses	Crushers	Mills	Lifts	Cranes	Conveyor belts	Ventilators	Refrigeration compressors	Compressors	Hydraulic pumps	Underwater pumps	Pumps	
														Typical Operational Behaviour
	●	●			●	●	●			●	●		●	Normal start
			●	●			○	●						Heavy load start
									●			●		Short start
				○		●	○	●	●	●	●	●	●	Continuous load
			●	●			●							Changing load
	●	●			●	●	○		○	○	○		○	Start - stop operation
	●	●	●	○		○								Short-term permissible overload
														Typical faults/protection requirements
	○	○	○	○		○	●	○	●	●	●	●	○	Starting time too long
	○	○	●	●	●	●	●	○	●	●	○	○	●	Stalling during start
	●	●	●	●		○	●							High overload during operation
	●	●	●	●	●	○	●	○	●	○	○	○	●	Stalling during operation
			○		○	○	●	●				●		Underload
	○	○	○	○	○	○	○	○	○	○	○		○	Earthing with "Holmgreen" method
	○	○	○	○	○	○	○	○	○	○	○	○	○	Earthing with cumulative current transformer
	●	●	●	●	●	●	●	●	●	●	●	●	●	Phase failure
	○	○	○	○	○	○	○	○	○	○	○	○	○	Asymmetry
	○	○	○	○			○	○						Thermally considered asymmetry
	○	○	●	●	○	●	○	○	○	○	○	○	○	Temperature sensor PTC in winding
	○	○	●	●	○	●	○	○	○	○	○	○	○	Temperature sensor PT 100 in winding
														Motor protection
														Requirements, suitable devices
										◇	◇		◆	Low: Bul 140 (+ Bul 817)
										◇	◇		◆	Low: 193EA (+ Bul 817)
	◇	◇			◇	◇	◇	◇	◇	◆	◆	◇	◇	Medium: CEFB 1; 193EB (+ Bul. 817)
	◆	◆			◇	◇	◇	◇	◇	◆	◆	◇	◇	Medium: SMP-3 (+ Bul. 817)
	◆	◆	◆	◆	◆	◆	◆	◆	◆	◆	◆	◆	◇	High: SMM 825

Optimum solution
 ○ = Possible
 ● = Typical

Motor protection
 ◇ = Possible solution
 ◆ = Optimum solution

7.2 Contactor selection depending on motor and drive

Motor / drive	Star-delta start	2-stage motors	frequency controlled 1)	Soft starters	Slip-ring motors	EEExe- motors	High voltage motors	Lv- motors >355 kW	Lv- motors >90...355 kW	Lv- motors >45...90 kW	Lv- motors <45 kW	
												Typical faults / protection requirement
	○	○		●	●	●	●	●	○			Stalling during start
	●	●	○	●	●	●	●	●	●	●		High overload during operation
	●	●	○	●	●	●	●	●	○			Stalling during operation
												Short-term permissible overload
							●					Short circuit (high voltage motors)
	○	○	○	○	○	○		○	●	●	●	Earthing with "Holmgreen" method
	○	○	○	○	○	○	●	●	○	○		Earthing with cumulative current transformer (core balanced CT)
	●	●	●	●	●	●	●	○	●	●	●	Phase failure
	●	●	●	○	○	○	●	●	●	○		Asymmetry
					○	○	●	●	●	○		Thermally considered asymmetry
					○	○	●	○	○			Thermally considered ambient temperature
			●		○	○		○	●	●	○	Temperature sensor PTC in winding
			●		○	○	●	●	●			Temperature sensor PT 100 in winding
												Motor protection
												Requirements, suitable devices
	◆	◇	◇	◇	◇							◆ Low: Bul. 140 (+ Bul. 817)
	◆	◇	◇	◇	◇	◆						◇ Low: 193-EA (+ Bul. 817)
	◆	◇	◇	◆	◆	◆		◇	◆	◇		◆ Medium: CEFB 1; 193-EB (+ Bul. 817)
	◆	◇	◇	◆	◆			◇	◆	◇		◆ Medium: SMP 3 (+ Bul. 817)
	◆	◆	◇	◆	◆	◆	◆	◆	◇	◇		◆ High: SMM 825

Typical faults / protection requirement

○ = Possible
● = Typical

Max. 400 Hz for pure sinusoidal current
10...400 Hz (CEFB 1-41/42)
In clarification
20 to 100Hz

Motor protection

◇ = Possible solution
◆ = Optimum solution

1) Restrictions
140
CEF 1-12
193-E, SMP 3
SMM 825

7.3 Protector selection depending on ambient conditions

Ambient condition					
Moisture	Dust	High temperatures	Large temperature fluctuations	No specific requirements	
					Protection function
	●	●	●		Temperature sensor PTC in winding
	●	●	●		Temperature sensor PT 100 in winding
	○	●	●		Thermally considered ambient temperature
●	○				Earthing with "Holmgreen" method
●	○				Earthing with cumulative current transformer
					Motor protection
					Requirements, suitable devices
	◆	◆	◇	◆	Low: Bul. 140 (+ Bul. 817)
	◆	◇	◇	◆	Low: 193-EA (+ Bul. 817)
	◆	◇	◇	◆	Medium: CEFB 1; 193-EB (+ Bul. 817)
	◇	◆	◇	◆	Medium: SMP 3 (+ Bul. 817)
	◆	◆	◆	◆	High: SMM 825

Protection functions

○ = Possible

● = Typical

Motor protection

◇ = Possible solution

◆ = Optimum solution

7.4 Protection selection in accordance with motor management criteria

MCC functions	Acknowledgement	Motor on/off	Diagnosis	Communication	Display, device	Statistics	Communication	Display, device	Warning	Communication	Display on device	Operational data	With communication	With detection relay	
															Useful warning functions
									●	●			●	●	Excessive starting time
									●	●			●	●	High overload during operation
									●	●			●	●	Earthing with cumulative current transformer
									●	●			●	●	Asymmetry
									●	●			●	●	Temperature sensor PT 100 in winding
															Useful operational data
									●	●			●	●	Motor current
									●	●			●	●	Asymmetry
									●	●			●	●	Earth current
									●	●			●	●	Temperature increase
									●	●			●	●	Stator temperature
															Motor management
															Requirements, useful devices
	◆	◆													Low: Bul. 140 + I/O Interface
	◆	◆													Low: 193-EA/EB, + I/O Interface
		◆	◇			◇		◇					◇		Medium: SMP 3
	◆	◆	◇			◇		◇					◇		Medium: SMP 3 + I/O Interface
			◆	◆		◆	◆	◆	◆				◆	◆	High: SMM 825
	◆	◆	◆	◆		◆	◆	◆	◆				◆	◆	High: SMM 825 + I/O Interface

Useful warning functions and operational data

○ = Possible
● = Typical

Motor management

◇ = Possible solution
◆ = Optimum solution



Rockwell Automation helps its customers receive a superior return on their investment by bringing together leading brands in industrial automation, creating a broad spectrum of easy-to-integrate products. These are supported by local technical resources available worldwide, a global network of system solutions providers, and the advanced technology resources of Rockwell.



Worldwide representation.

Argentinien • Australia • Austria • Bahrain • Belgium • Brazil • Bulgaria • Canada • Chile • China, PRC • Colombia • Costa Rica • Croatia • Cyprus • Czech Republic • Denmark • Ecuador • Egypt • El Salvador • Finland • France • Germany • Greece • Guatemala • Honduras • Hong Kong • Hungary • Iceland • India • Indonesia • Ireland • Israel • Italy • Jamaica • Japan • Jordan • Korea • Kuwait • Lebanon • Malaysia • Mexico • Netherlands • New Zealand • Norway • Pakistan • Peru • Philippines • Poland • Portugal • Puerto Rico • Qatar • Romania • Russia-CIS • Saudi Arabia • Singapore • Slovakia • Slovenia • South Africa, Republic • Spain • Sweden • Switzerland • Taiwan • Thailand • Turkey • United Arab Emirates • United Kingdom • United States • Uruguay • Venezuela • Yugoslavia

Rockwell Automation Headquarters, 1201 South Second Street, Milwaukee, WI 53204 USA, Tel: (1) 414 382-2000, Fax: (1) 414 382-4444

Rockwell Automation European Headquarters SA/NV, avenue Herrmann Debroxlaan, 46, 1160 Brussels, Belgium, Tel: (32) 2 663 06 00, Fax: (32) 2 663 06 40

Rockwell Automation Asia Pacific Headquarters, 27/F Citicorp Centre, 18 Whitfield Road, Causeway Bay, Hong Kong, Tel: (852) 2887 4788, Fax: (852) 2508 1846